

CNC Precision Universal ID & OD Grinder

EGM&EGI CNC · Printed in Taiwan · ES_06/2023 · en

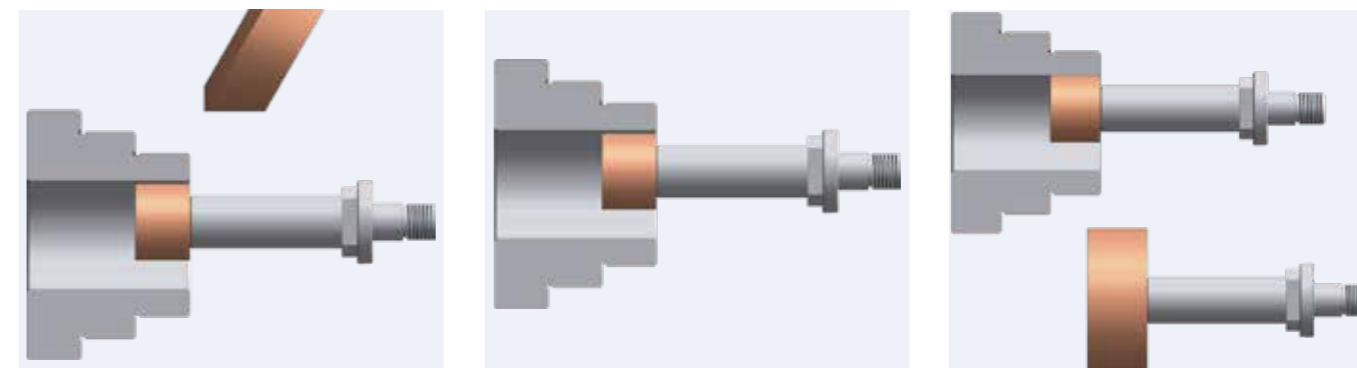

Grinder Professionals

e-tech USA

6435 Alondra Blvd, Paramount,
CA.90723

E-mail : info@supertecusa.com

TEL : (562) 220-1675

e-tech Asian Operation Center

No. 12, Longshan 2nd St., Daya Dist.,
Taichung City 42863,

Taiwan (R.O.C.)

E-mail : info@etechtw.com

TEL : 886-425686418

WEB: www.etechtw.com

1 EGM / EGI series CNC Precision Hybrid ID & OD Grinder

EGM350 CNC Universal precision grinder equips with X, Z, Y three axes slides and two grinding spindles. It is specially designed to keep up with the growing demand for extremely high precision parts.

Features

- EGM350 series CNC control systems are available for MITSUBISHI* or FANUC** control. It also can be operated with graphic conversational programming (Option) Therefore, it eliminates the need for G-code programming, and is easy to learn and use for grinding operation even for beginners.
(*MITSUBISHI M80 with touch screen / **FANUC 0i-TF)
- Low-gravity base structure and operation panel are designed to meet ergonomic requirement
- Combinations of grinding operations for internal, external, end-face, groove, radius, internal & external step, and taper grinding can be executed in one chucking. Thus, it highly increases grinding efficiency and also ensures better concentricity and accuracies of the ground parts.



EGM-350LCNC

CNC Controller

- Outstanding dressing function highly reduces dressing time (Mitsubishi M80)
- Optional graphic conversational programming for grinding and wheel dressing (Mitsubishi/Fanuc)
- Immediate dressing function during the grinding cycle can save time for the initial set-up.
- 10.4" color touch screen for Mitsubishi M80.
- Internal / External cylindricity compensating function.
- Min. increase input for X/Z/Y axes: 0.001mm.
- Programs can be stored for future use.
- Current anti-collision function.
- MPG simulation function to test-run for the program to avoid accidental wheel crash.



Standard grinding cycles and multi-steps graphic conversational functions.

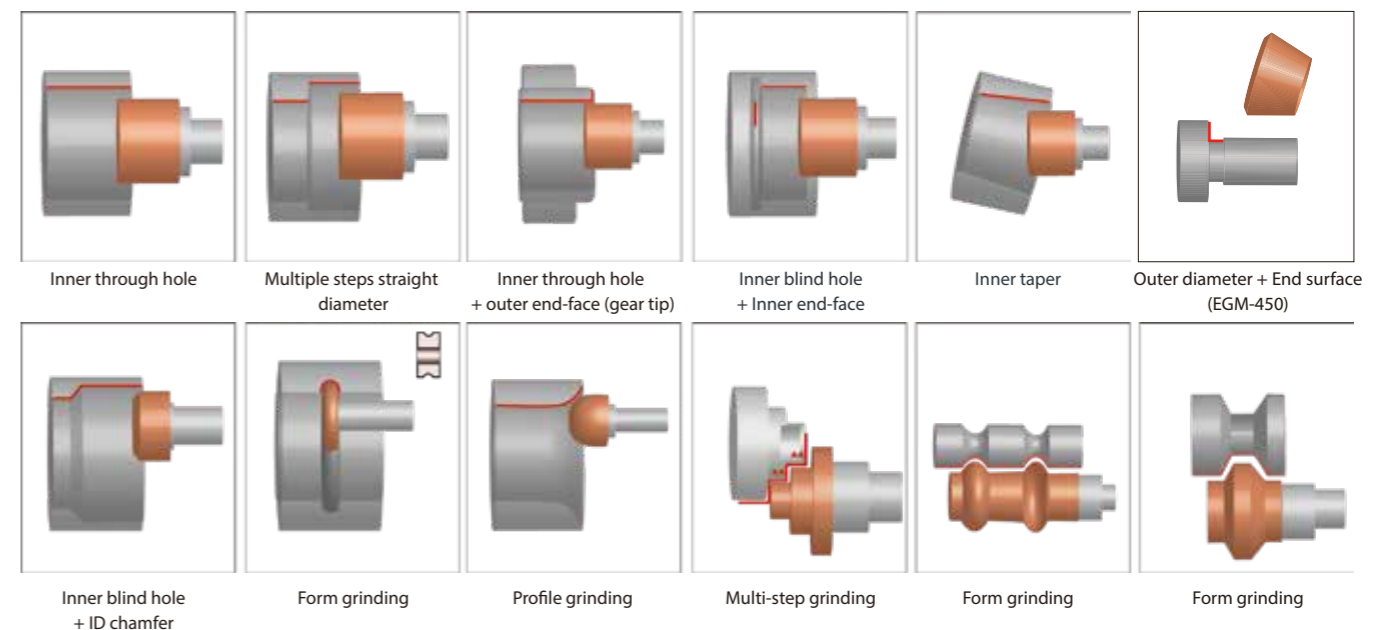

Grinding wheel dressing graphic illustration

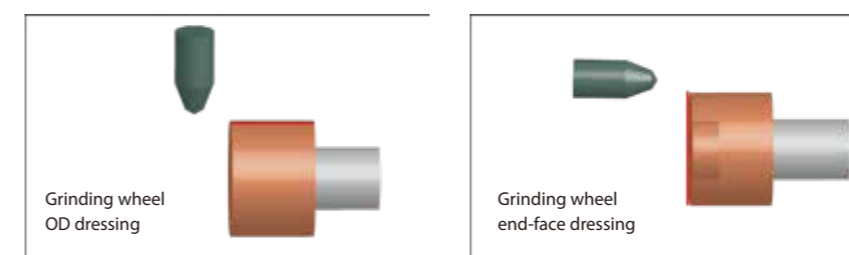



Complete one piece cartridge spindle can avoid the eccentricity of spindle housing and reduces the thermal growth, it increase spindle life-time .

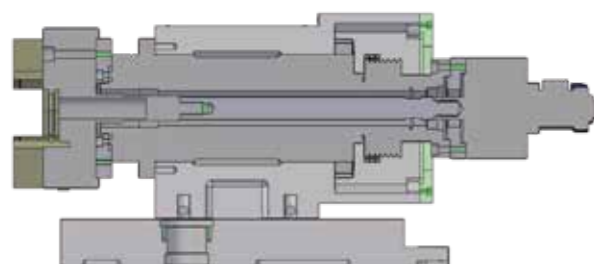

The spindle head design places the center of gravity at the rear portion to help balancing the whole spindle mechanism to increase spindle accuracy and loading capacity.

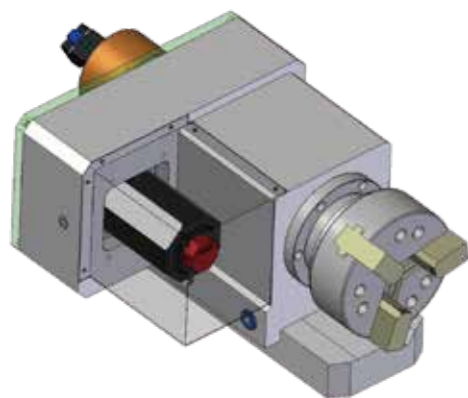

Spindle driven by servo motor offers optimum speed and torque performance.

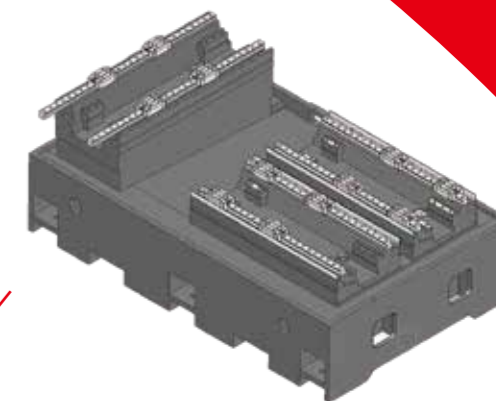
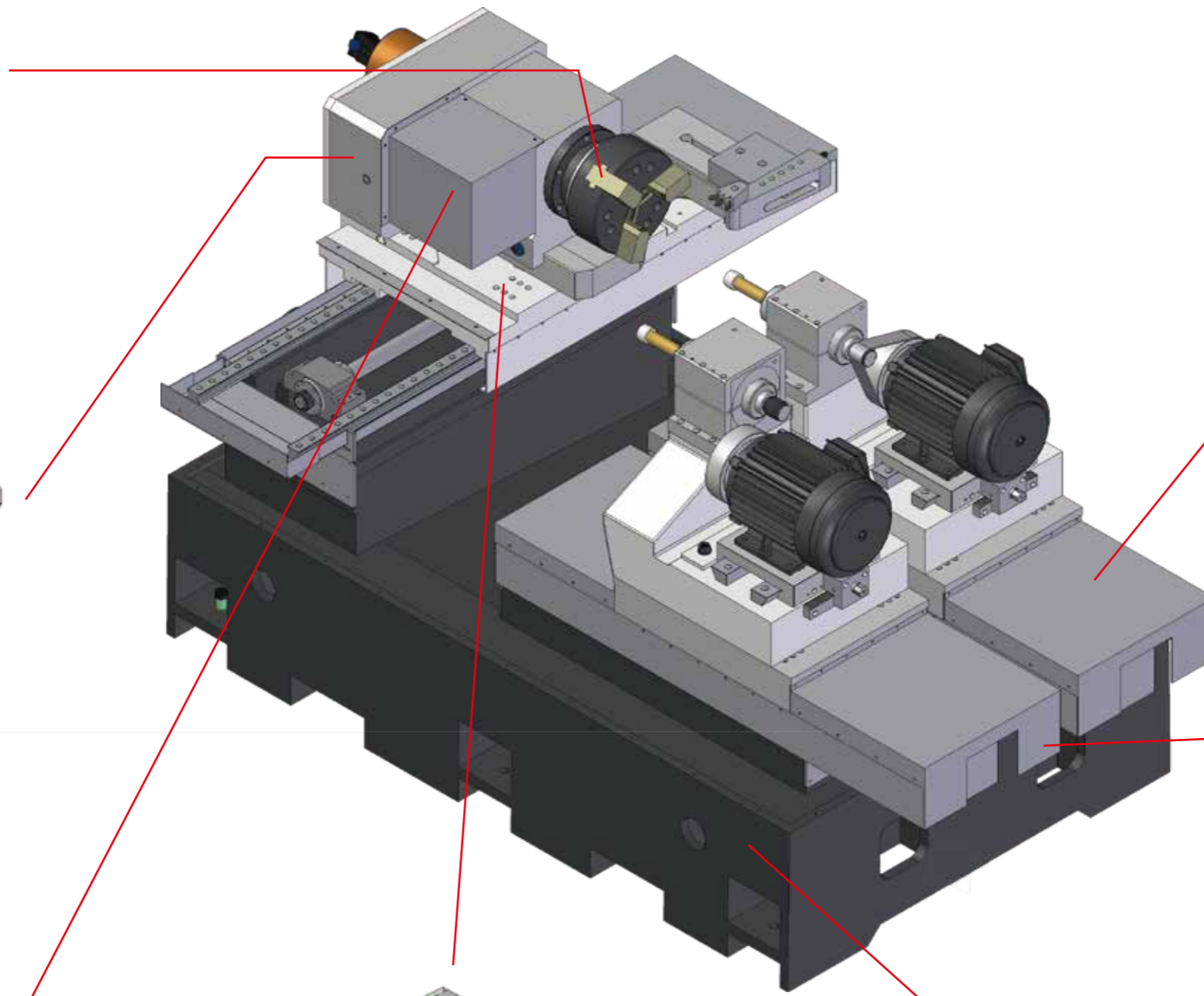

Machine is using roller type linear guide ways for X/Z/Y axes for high dynamic rigidity and better loading capacity. This drastically increases the grinding accuracy

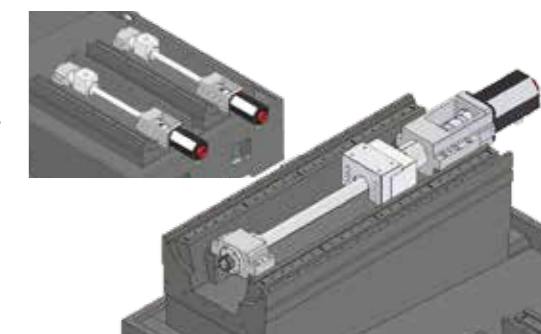

C1 grade precision ball screw with large leading pitch is used to achieve high accuracy.

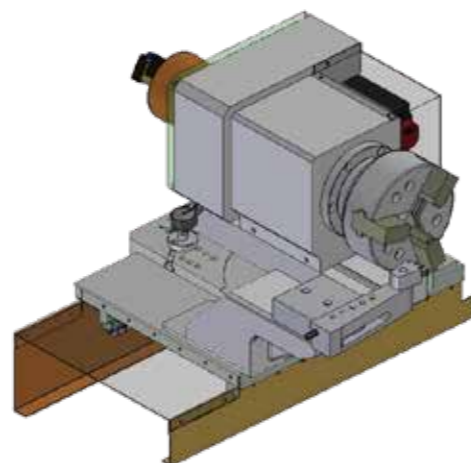

X axis lower slide design offers easy adjustment of the workhead for grinding parts with different lengths.

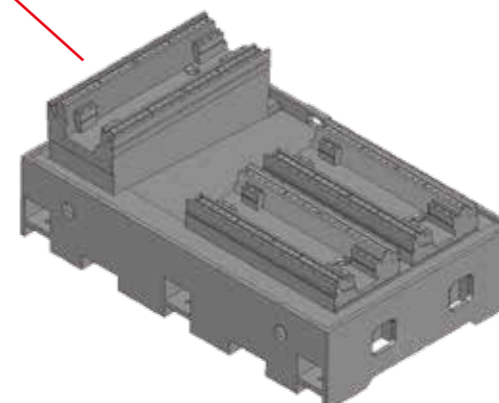

Low-gravity base structure, with slant bed design for better coolant draining and grinding swarf removal.

- Operation set-up through simple graphic display icons for easy learning progress.

Labels in the screenshot:

- Edit/Execute
- File Management
- Z axis GW Option
- Y axis GW Option
- Machine Position & Condition Display
- Sequence Setting: Select GW options & grinding modes
- Former Page
- Cycle Grinding Model
- Smart Operation
- Axial Compensation Selection

- Grinding cycle selection

ID	Inner-End-face	ID-Taper	Inner-Hook	Blind ID
OD	Outer-End-face	OD-Taper	Outer-Hook	Blind OD

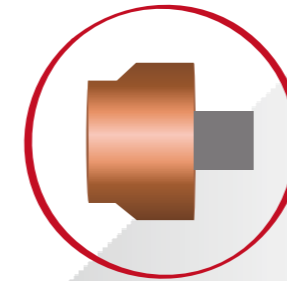

Type	K	Z	R/C
1	FINC	20.0000	0.0000
2	FINC	20.0000	10.0000
3	FINC	10.0000	10.0000
4	FINC	10.0000	10.0000
5	ACD+INC	-4.0000	4.0000
6	FINC	0.0000	12.0000
7			
8			
9			
10			

Grinding Wheel Dressing

With the iGrind outstanding dressing function, the operator just have to input the necessary parameters for the dresser and the geometric data of the profile to create the optimal dressing path. Thus, it drastically reduces the wheel dressing time.



Sequence setting:
Select grinding wheel options and grinding modes

Convenient and quick wheel dressing point setting

7 Grinding Example



ID auto. gauging device

Parts Name:

- Material : SCM415(JIS)
- Workpiece dimension : $\varnothing 90 \times 45 \times \varnothing 35 \text{mm}$
- Grinding application : 0.25mm/60 sec.
- Hardness : HRC55 $\pm 2^\circ$
- Dimension tolerance : 5 μm
- Grinding wheel speed : 20,000 rpm
- Roundness : 2 μm
- Cylindricity : 3 μm

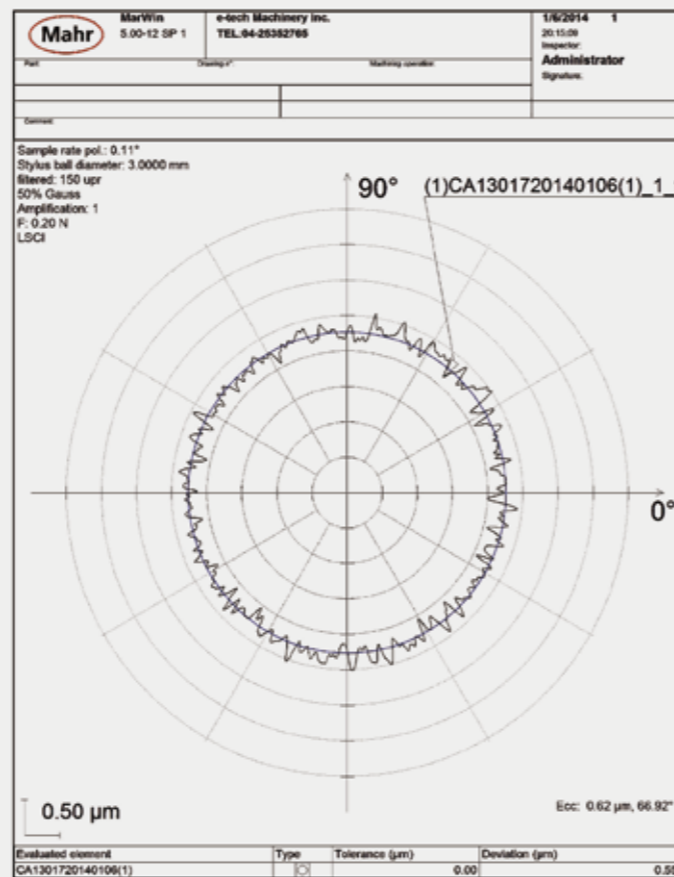
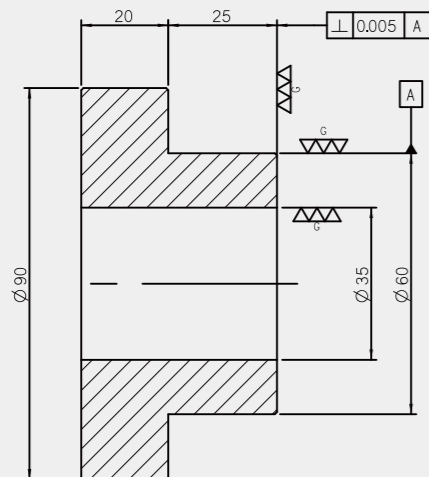

Grinding wheel spindle specification

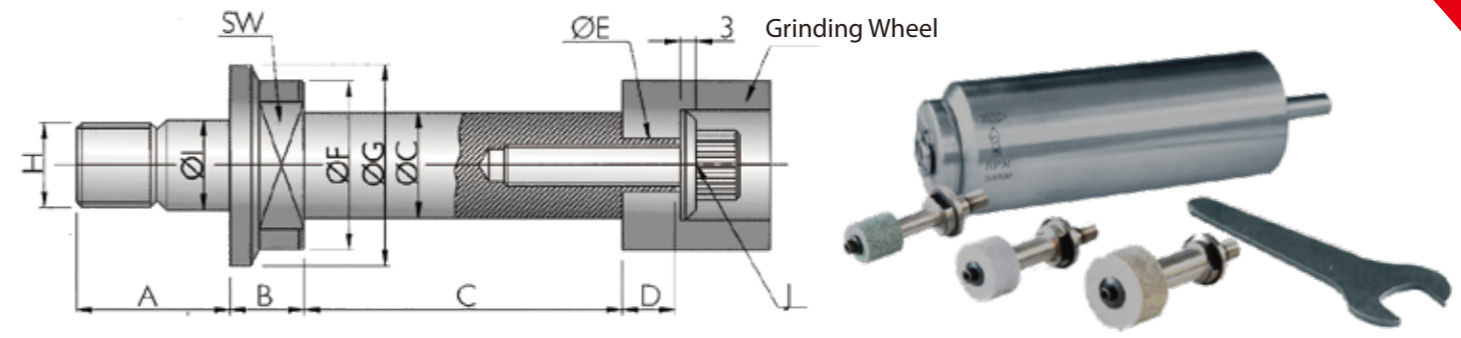

Suitable Inner Diameter	Grease Type	A	B	C	D	E	F	G	H	I	J	SW	Oil Mist Type	Suitable Inner Diameter
$\varnothing 65 \sim \varnothing 150$	8,000 rpm	42	16	$\varnothing 40 \times 100$ $\varnothing 40 \times 85$ $\varnothing 40 \times 55$	12	$\varnothing 12$	$\varnothing 50$	$\varnothing 58$	M26x2P	$\varnothing 28$	M8x1.25P	41	-	-
$\varnothing 35 \sim \varnothing 70$	15,000 rpm	29	14	$\varnothing 30 \times 90$ $\varnothing 25 \times 70$ $\varnothing 20 \times 50$	10	$\varnothing 10$	$\varnothing 32$	$\varnothing 38$	M16x1.5P	$\varnothing 17$	M8x1.25P	24	-	-
$\varnothing 24 \sim \varnothing 40$	20,000 rpm	28	11	$\varnothing 24 \times 80$ $\varnothing 20 \times 60$ $\varnothing 16 \times 40$	8	$\varnothing 8$	$\varnothing 26$	$\varnothing 32$	M14x1.5P	$\varnothing 15$	M6x1.0P	19	30,000 rpm	$\varnothing 15 \sim \varnothing 25$
$\varnothing 15 \sim \varnothing 25$	30,000 rpm	21	9	$\varnothing 16 \times 40$ $\varnothing 13 \times 30$ $\varnothing 10 \times 25$	6	$\varnothing 6$	$\varnothing 21$	$\varnothing 26$	M10x1.5P	$\varnothing 10.5$	M4x0.7P	17	40,000 rpm	$\varnothing 12 \sim \varnothing 16$
$\varnothing 12 \sim \varnothing 16$	40,000rpm	20	8	$\varnothing 12 \times 35$ $\varnothing 10 \times 30$ $\varnothing 8 \times 25$	x	x	$\varnothing 18$	$\varnothing 23$	M8x1.25P	$\varnothing 8.5$	M4x0.7P	14	50,000 rpm	$\varnothing 9 \sim \varnothing 13$
$\varnothing 9 \sim \varnothing 13$	50,000rpm	18	7	$\varnothing 8 \times 30$ $\varnothing 7 \times 25$ $\varnothing 6 \times 20$	x	x	$\varnothing 15$	$\varnothing 20$	M7x1P	$\varnothing 7.5$	M4x0.7P	11	60,000 rpm	$\varnothing 6 \sim \varnothing 10$

Standard Accessories:

- Control system: Mitsubishi M80 or FANUC 0i-TF with 10.4" screen
- Three-direction dresser stand x 1 set, diamond dresser x 3 pcs
- Wheel spindle surface detecting & crash control system (current indicator)
- Grease type grinding wheel spindle: (Select 2 pc from 8,000~50,000RPM)
- Hydraulic 8" 3-jaw chuck (w/ solid cylinder)
- MPG handwheel: EGI 2 Axes, EGM 3 Axes control
- Renishaw/Mitsubishi linear scale (resolution 0.05 μm)
- Electricity cabinet w/ heat exchanger
- Standard coolant tank 140L
- Automatic lubrication system

- 4-color indication signal light
- Levelling bolts and blocks
- Tools & tool box
- Electrical wiring diagram
- Operation manual & part lists
- Full-enclosed splash guard
- Workhead spindle A2-5
- Electrical lubricator
- LED working light

Optional accessories:

- Mitsubishi controller (M80) dressing program: Radius / Taper / Multiple step / form shape
- Mitsubishi controller (M80) iGrind program
- Coolant system with magnetic separator & paper filter
- Coolant system with magnetic separator
- Coolant system with paper filter
- CE standard electrical cabinet
- Electrical cabinet air conditioner
- Grease type grinding wheel spindle
- Oil mist type grinding wheel spindle
- Workhead spindle A2-6 (65mm thru-hole)
- Manual strong type 7" 3-jaw chuck
- Oil & mist collecting system
- Spindle oil mist lubrication system
- ID auto. gauging device
- Diamond roller dressing device
- Dressing sensor system
- Soft-Jaw turning assembly
- Workhead swivel w/ linear scale and DRO
- Safety door lock

Diamond roller dressing device



9 Specification : EGM & EGI Series

Model		EGI-150 CNC	EGM-350 CNC
General	Max. grinding ID	mm	Ø300
	Max. grinding OD	mm	Ø300
	Swing over workhead	mm	Ø500
	Max. grinding depth	mm	260
	Max. weight of workpiece	kg	50
	Max. length of workpiece	mm	300
	Type of wheel head		Single feeding wheelhead
Workhead	3-Jaw chuck	Hydraulic - 8"/10"(opt.)	Hydraulic - 8"/10"(opt.)
	(X Axis) Swiveling angle range	deg	+15°~ -5°
	Manual travel distance (toward Z axis)	mm	250
	Spindle speed	rpm	0~1000 (Variable speed)
Grinding wheelhead	OD grinding wheel size	mm	N/A
	(Y Axis) ID grinding wheel size	mm	N/A
	Max. spindle RPM	rpm	10,000 (std.)
	Spindle motor/ max. torque	kW/Nm	3.75kW / 13Nm
Grinding wheelhead	OD grinding wheel size	mm	N/A
	(Z Axis) ID grinding wheel size	mm	Ø100
	End-Surface grinding spindle (Opt.Z2)	mm	Ø80(CBN)
	Max. spindle RPM	rpm	20,000 (std.)
X Axis	Travel	mm	300
	Rapid feedrate	m/min	8
	Heidenhain linear scale resolution	um	0.05
	Min. increment	mm	0.0001
Y Axis	Travel	mm	N/A
	Rapid feedrate	m/min	N/A
	Min. increment	mm	N/A
	Servo motor rated power	kW	N/A
Z Axis	Travel	mm	350
	Rapid feedrate	m/min	8
	Min. increment	mm	0.0001
	Servo motor rated power	kW	1.8(F)/2.2(M)
Motor	Hydraulic motor	KW	0.75
	Coolant pump	KW	0.37+0.18
Machine	Net weight	kg	5000
	Gross weight	kg	5500
	Packing size (L x W x H)	mm	3350x2250x1950

Model		EGM-350L CNC	EGM-450 CNC
General	Max. grinding ID	mm	Ø300
	Max. grinding OD	mm	Ø330
	Swing over workhead	mm	Ø340
	Max. grinding depth	mm	260
	Max. weight of workpiece	kg	300 (w/ steady rest)
	Max. length of workpiece	mm	750
	Type of wheel head		Dual independent wheelhead
Workhead	3-Jaw chuck	Manual- 8"/10"(opt.)	Hydraulic - 8"/10"(opt.)
	(X Axis) Swiveling angle range	deg	+10°~ -5°
	Manual travel distance (toward Z axis)	mm	550
	Spindle speed	rpm	0~1000 (Variable speed)
Grinding wheelhead	OD grinding wheel size	mm	N/A
	(Y Axis) ID grinding wheel size	mm	Ø100
	Max. spindle RPM	rpm	10,000 (std.)
	Spindle motor/ max. torque	kW/Nm	3.75kW / 13Nm
Grinding wheelhead	OD grinding wheel size	mm	N/A
	(Z Axis) ID grinding wheel size	mm	Ø100
	End-Surface grinding spindle (Opt.Z2)	mm	N/A
	Max. spindle RPM	rpm	20,000 (std.)
X Axis	Travel	mm	420
	Rapid feedrate	m/min	8
	Heidenhain linear scale resolution	um	0.05
	Min. increment	mm	0.0001
Y Axis	Travel	mm	350
	Rapid feedrate	m/min	8
	Min. increment	mm	0.0001
	Servo motor rated power	kW	1.8(F)/2.2(M)
Z Axis	Travel	mm	350
	Rapid feedrate	m/min	8
	Min. increment	mm	0.0001
	Servo motor rated power	kW	1.8(F)/2.2(M)
Motor	Hydraulic motor	kW	0.75
	Coolant pump	kW	0.37+0.18
Machine	Net weight	kg	6800
	Gross weight	kg	7300
	Packing size (L x W x H)	mm	4000x2250x1950

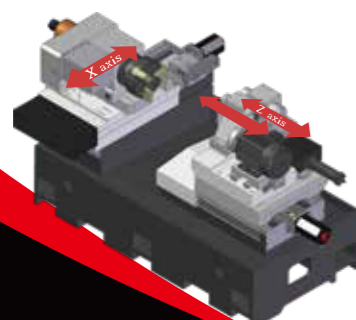

EGI-150CNC

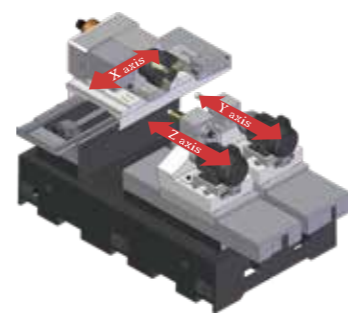

EGM-350CNC

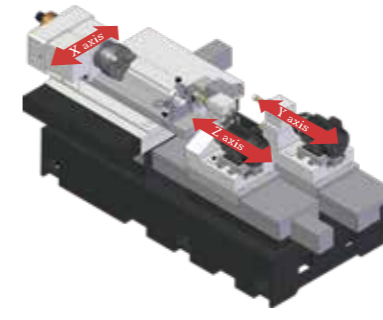

EGM-350LCNC

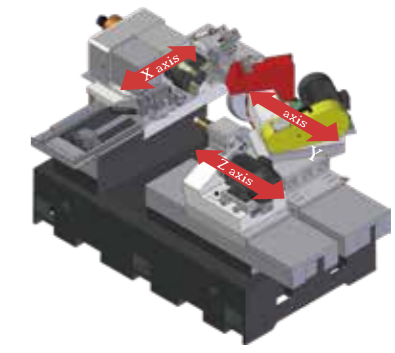

EGM-450CNC