

CNC Cylindrical Grinder

Mini Genie Series

Mini Genie CNC • Printed in Taiwan • E3 • 10/2021 • en

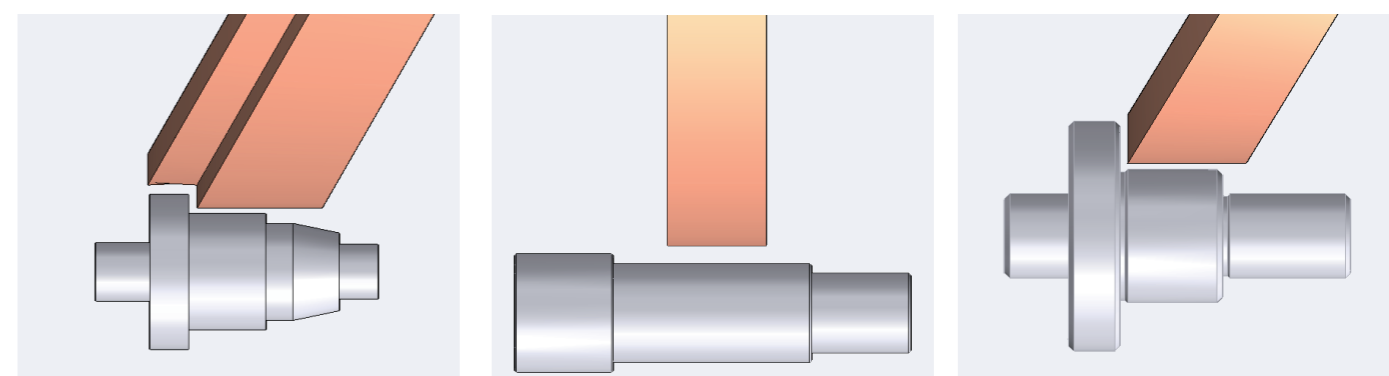

Grinder Professionals

e-tech USA

6435 Alondra Blvd, Paramount,
CA.90723

E-mail : info@supertecusa.com

TEL : (562) 220-1675

e-tech Asian Operation Center

No. 12, Longshan 2nd St., Daya Dist.,
Taichung City 42863,
Taiwan (R.O.C.)

E-mail : info@etechtw.com

TEL : 886-425686418

WEB : www.etechtw.com

1 EGP Series Mini Genie CNC Cylindrical Grinder

EGP Series grinders are designed for high precision, high efficiency, and ease of operation. They are suitable for various applications including but not limited to automatic, aerospace, medical instrument, tooling, job shop and mold industries.

Features

- Mini Genie is a high-efficiency cylindrical grinding machine with ultimate reduction in footprint. With a floorspace requirement of less than 3 square meter and 405/510mm diameter grinding wheel, it is suitable for small workpieces machining. Distance between center is designed to be 200mm, the center height is 110/130mm, and the maximum weight of workpiece can be processed is 20kg.



iGrind CNC Controller

- e-tech Machinery continues its years of software development experience with the introduction of iGrind, the easy to learn easy to program software on the Mini Genie grinders. It can grind various spare parts efficiently with the easy-setting software, and can be combined with multiple measurement systems or even automatic machining system.

Modular Automation Application

- e-tech is good at helping customers increase productivity. Through process modularization and automation, it can improve long-term processing efficiency and maintain accuracy stability.
- Mini Genie with robotic system is suitable for workpieces in small quantity and various styles.

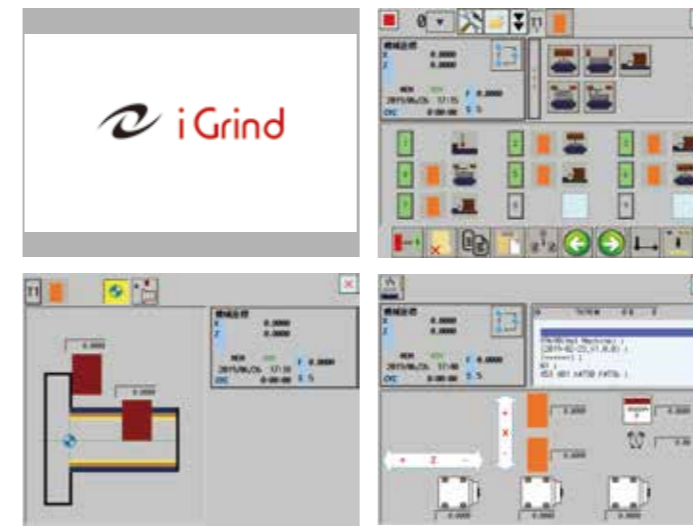

- OD Grinding / End Face Grinding / Form Grinding
- Form Dressing w/Auto Compensation
- Multiple Section Grinding Sequences
- Setup Parameter Storage
- Graphic Parameter Instruction

Wheel Dressing Cycle

Plunge Type

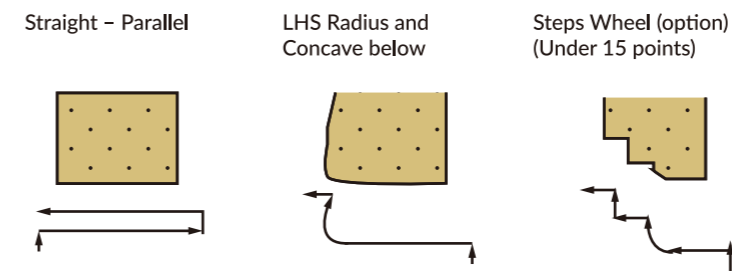

Angular Type

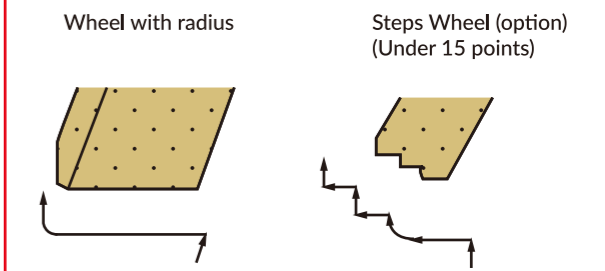

Remarks :

1. Max. 5 types of wheel profile can be saved.
2. Dressing condition can setup rough, intermediate and fine dressing
3. Machine with ID attachment, the dressing operation of ID wheel is manual operated.

Grinding Cycle

Plunge Type

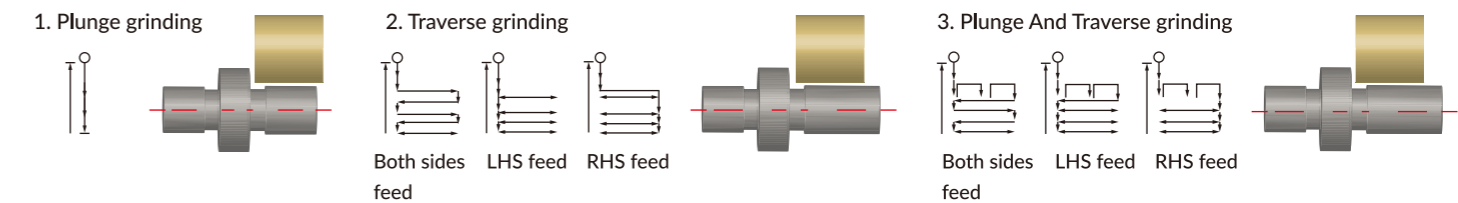

Angular Type

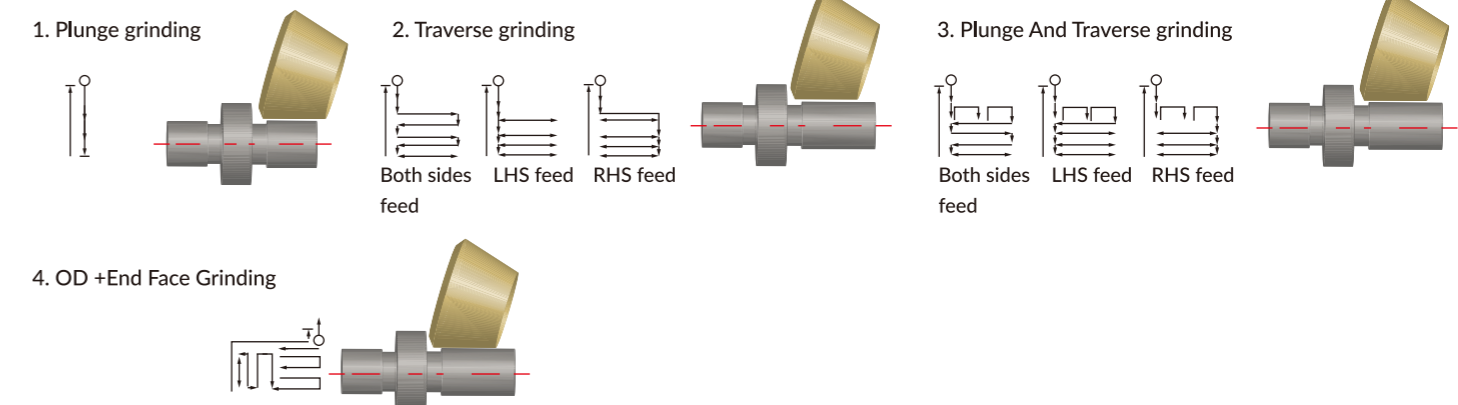



Work Head

NN bearing designed work spindle offers heavy duty load capacity, optimal rotation accuracy, and high rigidity. The servo motor drive offers steady speed and torque during the grinding operation. A positive air purge system keeps grinding swarf and coolant out of the work head, thus it prolongs its life.

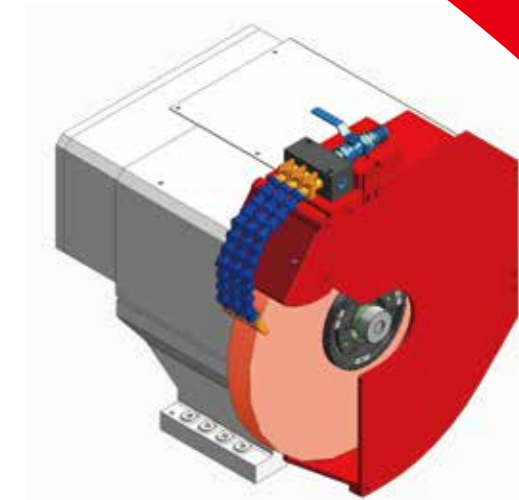

Wheel Head

NN bearing designed work spindle with high power motor provides enough power to outer diameter 405mm of wheel head, and improves processing efficiency. The angle of wheel head could be choose as 0 or 20 degree.

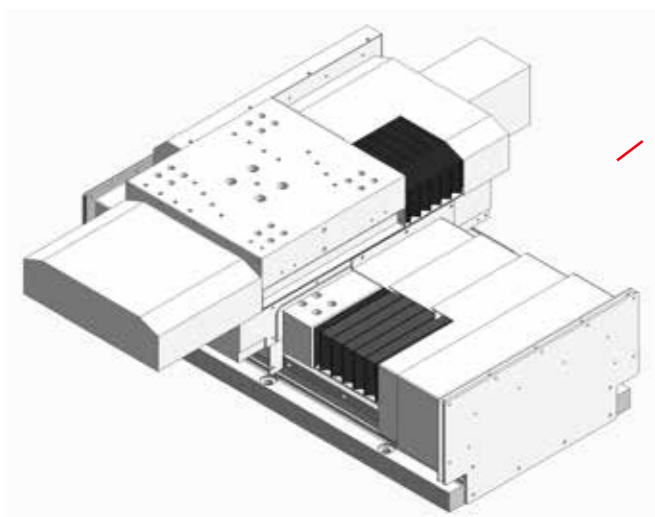
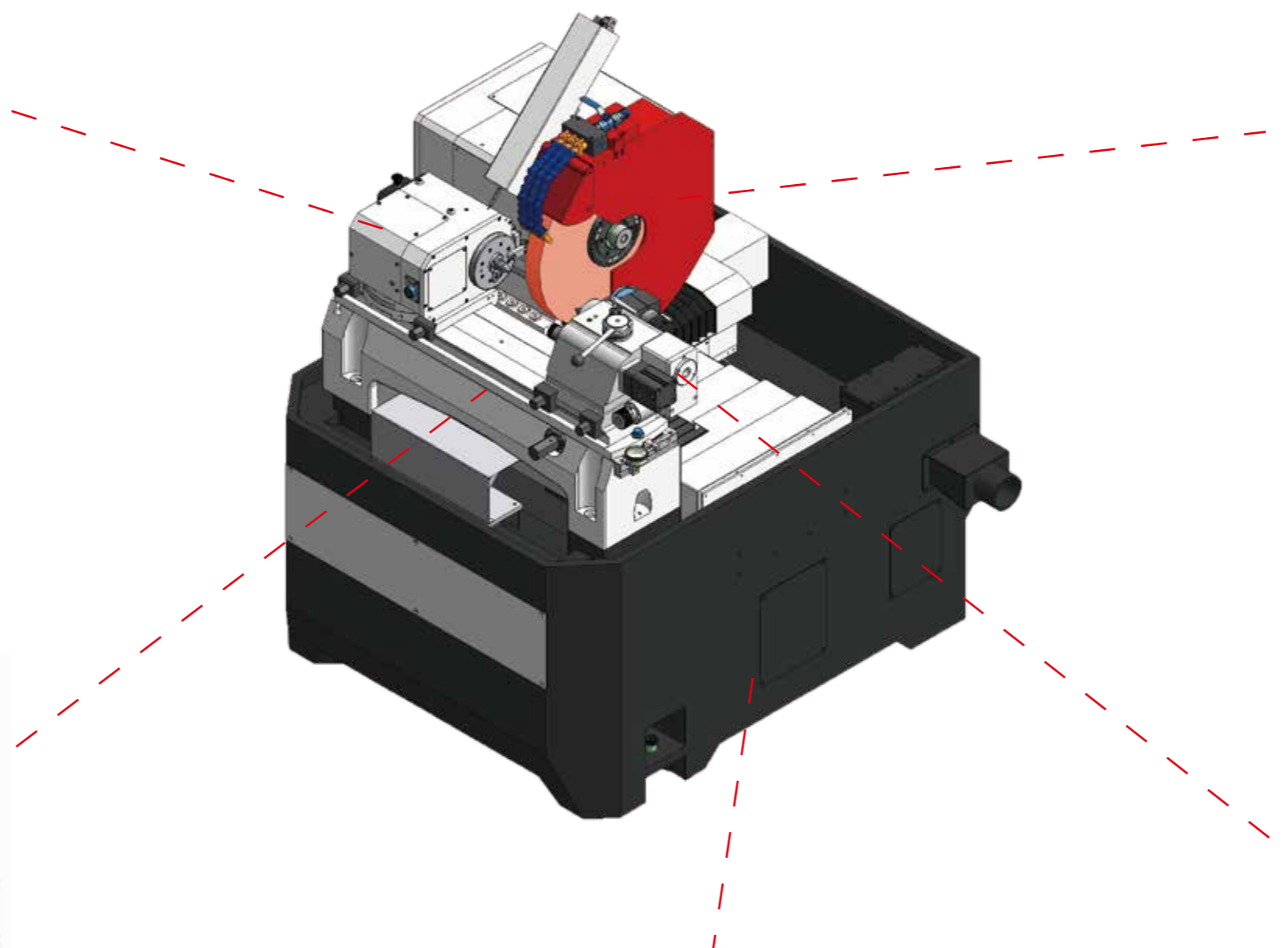

Cross Slides

The structure of cross slides is made of Meehanite cast iron. Its good thermostability compensates for temporary temperature changes. (Roller bearing and straight lead rail with Heidenhain linear scale)

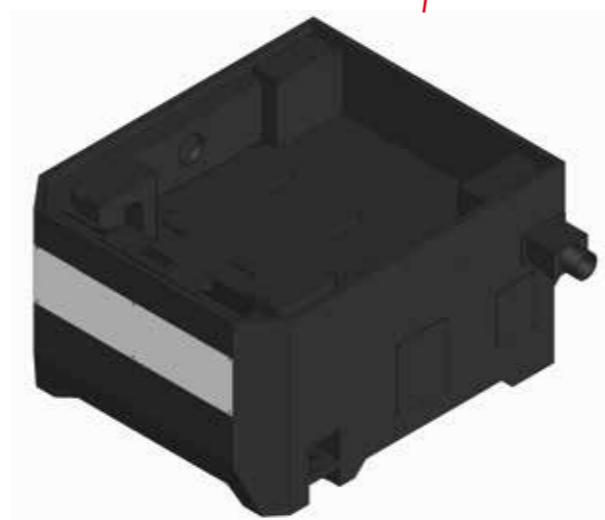

Machine Base

Bath type of machine base is made in Meehanite cast iron, which experience natural aging and twice stress relief to make machine base itself more stable and durable.

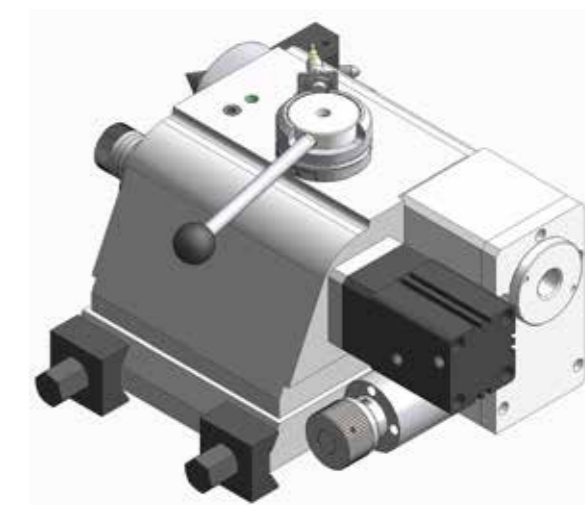

Tail Stock

Oil-bath tail stock remains lubrication and makes the machine more durable. Tailstock taper adjustment feature makes workpiece setting faster.

Model		EGP-2020	EGP-2520	
Grinding	Swing over table	mm	φ210	φ250
Capacity	Distance between centers	mm	200	200
	Max. grinding diameter	mm	φ200	φ230
	Max. load held between center	kg	20	20
	Center distance between spindle and slide table	mm	110	130
Grinding Wheel	Diameter x Width x Bore	mm	φ405×50×φ127	φ510×50×φ152.4
Wheel	Motor rapid power / max. torque	Kw/Nm	3.7/17.7	5.5/27.6
	Wheel speed	rpm	1570 (Opt.2100)	1250 (Opt.1650)
	Spindle type	-	bearing spindle	bearing spindle
	Wheel head angle	deg	0 or 20	0 or 20
Work Head	Max. manual swiveling angle	deg	90	90
	Spindle speed (infinite variable)	rpm	10 ~ 600	10 ~ 600
	Motor rated power / max. torque	kw	0.75	0.75
	Center taper	-	MT3	MT3 (Opt. MT4)
	Center working	-	Fixed or Rotary	Fixed or Rotary
	Diameter of bore	mm	φ20	φ20
Tailstock	Tailstock quill travel	mm	25	25
	Center taper	-	MT3	MT3 (Opt. MT4)
	Micro-taper adjustment	mm	±0.04	±0.04
X Axis	Travel	mm	200	200
	Max. rapid feedrate	m/min	6	6
	Heidenhain linear scale resolution	um	0.05	0.05
	Min. increment	mm	0.0001	0.0001
	Servo motor rated power	Kw	1.2(F) / 1.5(M)	1.2(F) / 1.5(M)
	Guide way	-	linear way	linear way
Z Axis	Travel	mm	300	300
	Swiveling angle	deg	+8° ~ -3°	+8° ~ -3°
	Max. rapid feedrate	m/min	8	8
	Min. increment	mm	0.0001	0.0001
	Servo motor rated power	Kw	1.2(F) / 1.5(M)	1.2(F) / 1.5(M)
	Guide way	-	linear way	linear way
Motor	Hydraulic pump	Kw	0.38	0.38
	Coolant pump	Kw	0.2	0.2
Machine	Net Weight	kg	2500	2500
	Measurement	mm	1300 x 2300 x 2000	1300 x 2300 x 2050

Measurement

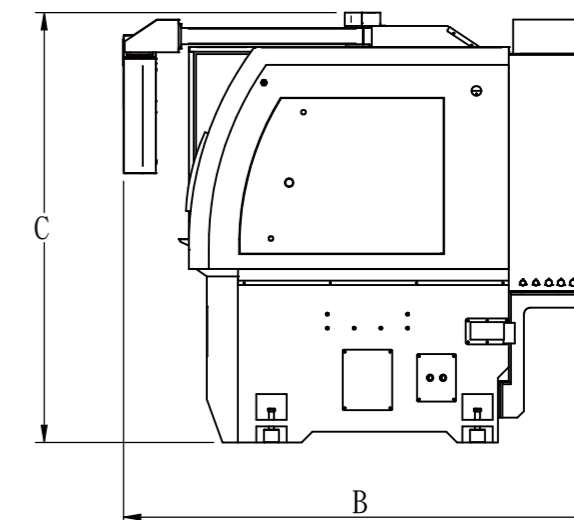
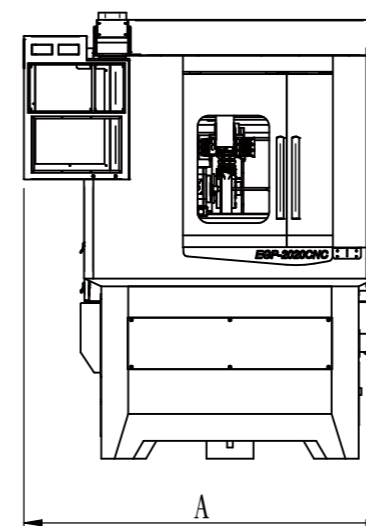

EGP	A	B	C
2020	1608	2212	1993
2520	1608	2212	2043

Standard Accessories

- Infinite variable workhead w/servo motor
- Fanuc CNC Controller (0i TF) /(Opt.Mitsubishi M80)
- Carbide center tip (MT3/C10)
- Diamond Dresser and Stand
- Automatic wheel speed change (15 steps)
- X Axis Heidenhain/Mitsubishi linear scale (resolution 0.05 um)
- Levelling bolts and blocks
- Operation manual and part lists
- Grinding wheel + Wheel flange
- Full-enclosed splash guard
- Standard coolant tank 140L
- MPG handwheel 2 Axes control
- Automatic lubrication system
- Roller type balancing stand/arbor
- LED working light
- Tools and Tool Box
- Electricity cabinet w/ heat exchanger
- Wheel extractor
- 4-color indication signal light
- Electrical wiring diagram

Optional Accessories

- FANUC 0i-TF iGrind program
- Mitsubishi controller (M80) iGrind program
- Electrical cabinet air conditioner
- Workhead upgrade to MT4 (EGP-2520CNC only)
- Tailstock upgrade to MT4 (EGP-2520CNC only)
- Roller type balancing stand/ arbor
- CE standard electrical cabinet
- Automation with robot arm
- Touch probe
- Transformer
- Workpiece carrier
- Workpiece supporting seat, 2pc / set (EGP-2520CNC only)
- 2 Point Steady Rest (EGP-2520CNC only)
- 3-jaw scroll chuck (EGP-2520CNC only)
- BS VM15 Integration system (OD gauging+ crash & gap control)
- Hydraulic tailstock (w/ foot pedal)
- Z Axis Heidenhain/Mitsubishi linear scale (resolution 0.05 um)
- Manual grinding wheel balance system (vibrator)
- Gap & crash control device
- Safety door lock
- Automatic gauging device
- Coolant system with magnetic separator & paper filter
- Coolant system with magnetic separator
- Coolant system with paper filter
- Oil & mist collecting system
- Spare grinding wheel flange
- Full-carbide center tip

* e-tech reserves the right to change specifications without notice