

# **HURISE**<sup>®</sup>

The leading brand of  
internal grinders in Taiwan



## Your will Our wheel

**CNC Multi-Function (ID / OD) Grinder  
for Long Sized Work Pieces**

**CNC Multi-Function (ID / OD) Grinder**

**CNC / NC Internal Grinder**

**High Speed Grinding Spindle  
for Grinders**



## Company Profile

"Hurise Co., Ltd" has 40 years of working experience grinding processing and manufacturing grinding machines such as hydraulic internal grinder, external grinder, surface grinder and centerless grinder. We have specialized in internal grinding technology since 1994 and the machine "Auto hydraulic internal grinder" had obtained several patents and has been highly recommended by customers.

Due to market demands, "Hurise" has started to work on CNC internal grinders since 2001. Our patented machine "CNC Multi-Function ID/OD Grinder" is the first grinding machine in Taiwan with "Twin Grinding Wheel Spindles" which can process inner/outer diameters, faces and tapers at the same cycle. It is an excellent choice to grind the industrial hardware especially for those need precision processing, like automobile parts, electronic industry, aerospace industry, defense industry, sewing parts and so on. Because of the twin grindings innovative technology, high efficiency and outstanding quality, it was awarded the "12<sup>th</sup> Small and Medium Enterprise Innovation Research Award" by the Ministry of Economy Affairs and has acquired multiple patents.

"Hurise" is built upon the belief that providing high quality products, customer services and constantly investing in the most state of art technologies are crucial to success. Armed with the support from staff and customers, "Hurise" has grown steadily. With the goal to expand the market globally, we will keep the same business concept and continue to provide excellent service for our loyal supporters.



**D2 CNC Multi-Function (ID/OD) Grinder for Long Sized Work Pieces**



**D1 CNC Multi-Function (ID/OD) Grinder**



**S10-F CNC Internal Grinder**



**S10 NC Internal Grinder**



**S10 NC Internal Grinder (Semi Cover)**

## Full Range of Grinder Series

Due to the industry's demands regarding processing precision and diversification requirements, "Hurise"'s renovated design of machinery manufactured the most high quality and efficient products, allowing the customers to reap the maximum profit.

## Introduction of Internal Grinder

The main purpose of internal grinder is to grind the internal diameter of work pieces for the final machining. Conventional internal grinders with a single grinding wheel spindle can only work for relatively simple work pieces, suitable for mass production.

The demands in superior machining concentricity in automotive, aerospace and industrial parts require higher precision concentricity for multiple machined faces that conventional internal grinders cannot achieve. To meet the needs of the market, "Hurise" develops an innovative and efficient "CNC Multi-Function ID/OD Grinder." This grinder is equipped with "twin grinding wheel spindles" and "high-end control system" designed to enhance the performance of grinding multiple faces, such as ID, OD, surface, end face, and taper.





## D2 CNC Multi-Function (ID / OD) Grinder for Long Sized Work Pieces



### Designed for Grinding Shaft Work Pieces

The unique design of the steady rest allows the work pieces to be loaded up to 1000mm long and enhance its accuracy and lifetime.



# D2 CNC Multi-Function (ID / OD) Grinder for Long Sized Work Pieces



## Superior Control System

The utilization of the FANUC control system combined with "Hurise"'s designed software is user-friendly while maximizing the efficiency of the machining process.



## Patented Twin Grinding Wheel Spindles



The patented twin grinding wheel spindles can grind 16 different faces at one cycle.

The grinder adopts the Uniaxial movement designed to eliminate the error occurred by the vibration of conventional methods.



## Precision Angle Fine-Tune

The work head angle is adjustable with automatic locking features. Furthermore, the advanced angle optical scale with resolution of  $0.0001^\circ$  significantly improve the efficiency and accuracy in fine-tuning the angle.



# D1 CNC Multi-Function (ID / OD) Grinder



## Designed for Diversification Work Pieces

The patented "Twin Wheel Grinding Spindles" can grind ID/OD, Inner/Outer end face, and taper at one cycle, increasing the concentricity and efficiency of the production.



# D1 CNC Multi-Function (ID / OD) Grinder



## User-friendly Operation Interface



Our outstanding R&D team, standing on the needs of the users to design all kinds of machining possibility for various work pieces. The flexible programming software, giving users diverse solutions.

## Internationally Recognized Control System



The electronic system uses inner circulation which locks out humidity and prevent the mechanical parts from overheating.

## Rapid Grinding Design

Besides dimension precision grinding system, the patented design "automatic sensing device" can quickly detect the contact surface of the ID/OD, inner/outer end faces for rapid and small amount face grinding. It is significant saving in processing time, and increasing machining efficiency.



## High Stability of Poly Granite Base

We also offer a poly granite base as an option, which increase the stability of machine base.





# S10-F CNC Internal Grinder (Full Cover / Semi Cover)



(Full Cover)

## Multiple Faces Grinding

Equipped with "FANUC" CNC control system for grinding "ID," "end face," and "taper" up to 8 different faces in ONE clamping.





# S10-F CNC Internal Grinder (Full Cover / Semi Cover)



## Digitized Internal Grinder

In response to the digitized operation in the machine industry, our CNC and NC internal grinders are equipped with advanced computer numerical control system. Compared to conventional hydraulic internal grinder, our CNC and NC type grinders have higher stability and accuracy, making it suitable for a mass and automation production.



## Solid Body Structure

The structure of the machine has a solid base consists of high density cast iron, enabling precise performance. Due to its sturdy design, damages to the machine can be avoided.

## Uniaxial Movement

The utilization of axial movement is revolutionary compared to the conventional method using the cross stacking movement. To avoid deviation caused by the vibration of mechanical movements can endure stability and precision during the grinding process.



# S10 NC Internal Grinder (Full Cover / Semi Cover)



(Full Cover)



(Semi Cover)

# S10 NC Internal Grinder (Full Cover / Semi Cover)



## High-End Components

Equipped with High-End "linear guideway", "ball screw", plus "automatic lubricating system" to extend machine life time and ensure the stability of grinding accuracy.

## Grinding Efficiency

The machine is designed to be efficient and stable during machining processing, making it perfect for mass production of simple work pieces.

## Excellent Grinding Equipment for Mass Production

S10 NC internal grinder is equipped with "Omron" control system, which is made in Japan. The user interface consists of graphics that are easy to understand, shortening the learning curve thus enabling a systematic production.



## Brand New Face Grinding Attachment (Optional)

The attachment is suitable for the mass production of faces grinding with user-friendly features designed to increase efficiency during production.





## High Speed Grinding Spindles for Grinders

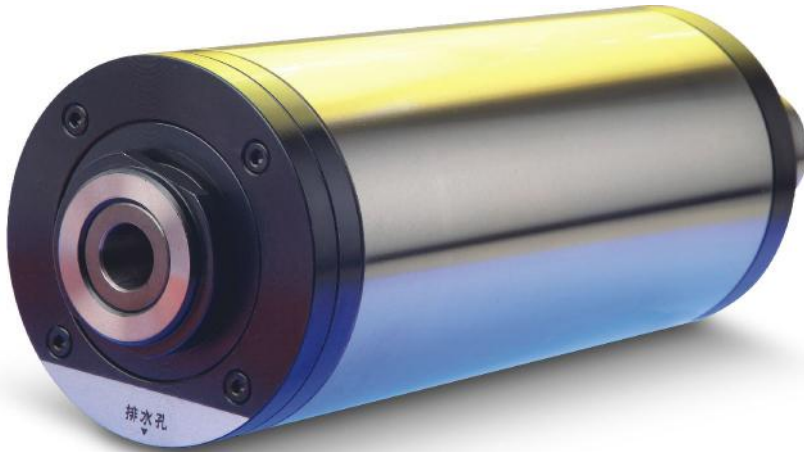

### Rigid, Efficient and Outstanding

- Grinding wheel spindles (belt type) are available.
- Every spindle undergoes a rigorous inspection to ensure the quality of the product.
- The patented waterproof design extend the life of grinding wheel spindles.
- With decades of grinding wheel spindles manufacturing experiences, we continue to invest in new technology to ensure the spindles are rigid, efficient and outstanding.

### Spindle specifications

r.p.m.	8,000	10,000 / 15,000 20,000 / 30,000	40,000 / 50,000
Bearing Material	Steel ball	Steel ball	Ceramic ball
Bearing lubrication	Grease	Grease	Grease
Transmission	Belt	Belt	Belt
Taper deflection	0.002 mm	0.002 mm	0.002 mm
Test bar deflection	0.003 mm	0.003 mm	0.003 mm
Installation	Horizontal	Horizontal	Horizontal
Diameter	90 mm	90 mm	90 mm
Weight	15.9kgs	11kgs	11kgs



Award

The model D1-CNC Multi-Function ID/OD Grinder was awarded the "12<sup>th</sup> Small and Medium Enterprise Innovation Research Award" by the Ministry of Economic Affairs.

Taiwan patents:  
209526、202534、M254300、M340885 etc.



Award

The model D2-CNC Multi-Function ID/OD Grinder was awarded the "20<sup>th</sup> Small and Medium Enterprise Innovation Research Award" by the Ministry of Economic Affairs.

Taiwan patents:  
102203879、101224871、101224872 etc.





## Grinder Specifications

### Specifications

Model	D1	D2
Swivel over table dia.	∅ 500 mm	∅ 320 mm
Workhead Speed	0 - 1,000 r.p.m.	0 - 1,000 r.p.m.
Workhead swivel by manual	+15° & -5°	+15° & -5°
X-axis max. travel	350 mm	450 mm
Y axis max. travel	350+250 mm	350 mm
Z-axis max. travel	350+250 mm	350 mm
Grinding capacity	∅ 2~400 mm	∅ 2~320 mm
Max. grinding diameter	∅ 320 mm	∅ 320 mm
Max. grinding depth	250 mm	250 mm
Max. grinding faces	16	16
Max. workpiece weight	50 kgs	300 kgs (W / Steady Rest)
X-axis speed	0~10,000 mm / min	0~10,000 mm / min
Y-axis speed	0~10,000 mm / min	0~10,000 mm / min
Z-axis speed	0~10,000 mm / min	0~10,000 mm / min
X-axis min. travel unit	0.0001 mm	0.0001 mm
Y-axis min. travel unit	0.0001 mm	0.0001 mm
Z axis min. travel unit	0.0001 mm	0.0001 mm
Workhead motor	1.5 kw, 4p	1.5 kw, 4p
Y-axis grinding wheel motor	2.2 kw, 2p	2.2 kw, 2p
Z-axis grinding wheel motor	2.2 kw, 2p	2.2 kw, 2p
Electricity requirement	15 kw	15 kw
Machine Dimensions	2365(W) x 1880(D) x 1830(H) mm	3650(W) x 1950(D) x 1960(H) mm
Space requirement for installation	3450(W) x 2860(D) x 2350(H) mm	4610(W) x 2810(D) x 2370(H) mm
Machine weight	4,000 kgs	6,100 kgs



## Specifications

Model	S10-F	S10
Swivel over table dia.	∅ 400 mm	∅ 400 mm
Workhead Speed	0 - 1,000 r.p.m.	0 - 1,000 r.p.m.
Workhead swivel by manual	+15° & -5°	+15° & -5°
X-axis max. travel	200 mm	200 mm
Z-axis max. travel	330+200 mm	330+200 mm
Grinding capacity	∅ 2~300 mm	∅ 2~300 mm
Max. grinding diameter	∅ 60 mm	∅ 60 mm
Max. grinding depth	200 mm	200 mm
Max. grinding faces	8	1
Max. workpiece weight	45 kgs	45 kgs
X-axis speed	0~10,000 mm / min	0~10,000 mm / min
Z-axis speed	0~10,000 mm / min	0~10,000 mm / min
X-axis min. travel unit	0.0001 mm	0.001 mm
Z axis min. travel unit	0.0001 mm	0.001 mm
Workhead motor	1.5 kw, 4p	1.5 kw, 4p
Z-axis grinding wheel motor	2.2 kw, 2p	2.2 kw, 2p
Electricity requirement	10kw	10 kw
Machine Dimensions	2300(W) x 1350(D) x 1810(H) mm	2260(W) x 1540(D) x 1615(H) mm
Space requirement for installation	3370(W) x 2250(D) x 2410(H) mm	2930(W) x 1940(D) x 2140(H) mm
Machine weight	3,000 kgs	3,000 kgs



## Grinder Specifications

### Standard Accessories

Model	D1	D2	S10-F	S10
FANUC control system	⊙	⊙	⊙	—
OMRON control system	—	—	—	⊙
X / Y / Z-axis FANUC servo motor	⊙	⊙	—	—
X / Z-axis FANUC servo motor	—	—	⊙	—
X / Z-axis OMRON servo motor	—	—	—	⊙
X / Y / Z-axis Linear Guideway	⊙	⊙	—	—
X / Z-axis Linear Guideway	—	—	⊙	⊙
X / Y / Z-axis ball screw	⊙	⊙	—	—
X / Z-axis ball screw	—	—	⊙	⊙
Automatic sensing device	⊙	⊙	⊙	—
Stationary dressing device	4 - Way	4 - Way	4 - Way	1 - Way
Active lubrication mechanism	⊙	⊙	⊙	⊙
Cover	Full	Full	Semi	Semi
Working lamp	⊙	⊙	⊙	⊙
Warning lamp (3 colors)	⊙	⊙	⊙	⊙
Toolbox	⊙	⊙	⊙	⊙

### Optional Accessories

Hydraulic chuck

Manual chuck

Coolant tank and filtering system (including oil skimmer, magnetic separator and paper filter)

Face grinding attachment (for S10 & S10-F with semi cover)

Full splash guard (for S10 & S10-F)

Oil mist collector

Working door safety locking system

Grinding wheel spindle (8,000~50,000rpm)

Steady rest (for D2)

Poly granite base - (for D1)



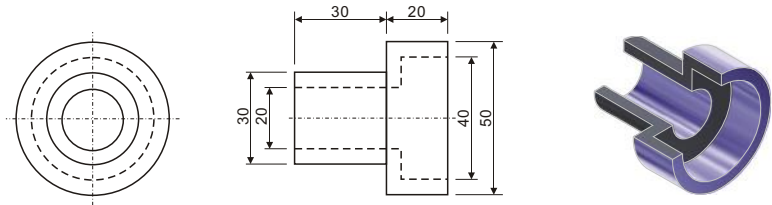

Example (unit: mm)

## Report

Model	D1	D2	S10-F	S10
ID Roundness	<0.001 mm	<0.001 mm	<0.001 mm	<0.001 mm
ID Cylindricity	<0.001 mm	<0.001 mm	<0.001 mm	<0.001 mm
OD Roundness	<0.001 mm	<0.001 mm	---	---
OD Cylindricity	<0.001 mm	<0.001 mm	---	---
ID Tolerance	<0.003 mm	<0.003 mm	<0.003 mm	<0.003 mm
Face Tolerance	<0.001 mm	<0.001 mm	<0.001 mm	---
ID Roughness	Ra0.2~0.3	Ra0.2~0.3	Ra0.2~0.3	Ra0.2~0.3
OD Roughness	Ra0.2~0.3	Ra0.2~0.3	---	---
Face Roughness	Ra0.6~0.8	Ra0.6~0.8	Ra0.6~0.8	---
ID/Face Perpendicularity	<0.002 mm	<0.002 mm	<0.002 mm	---

## Samples

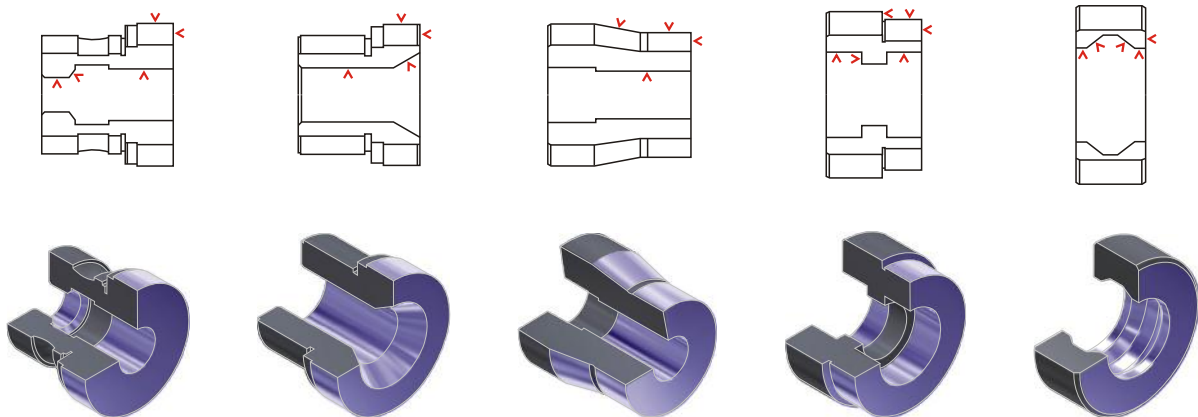



## Machine Dimensions

### D2 CNC Multi-Function (ID / OD) Grinder for Long Sized Work Pieces

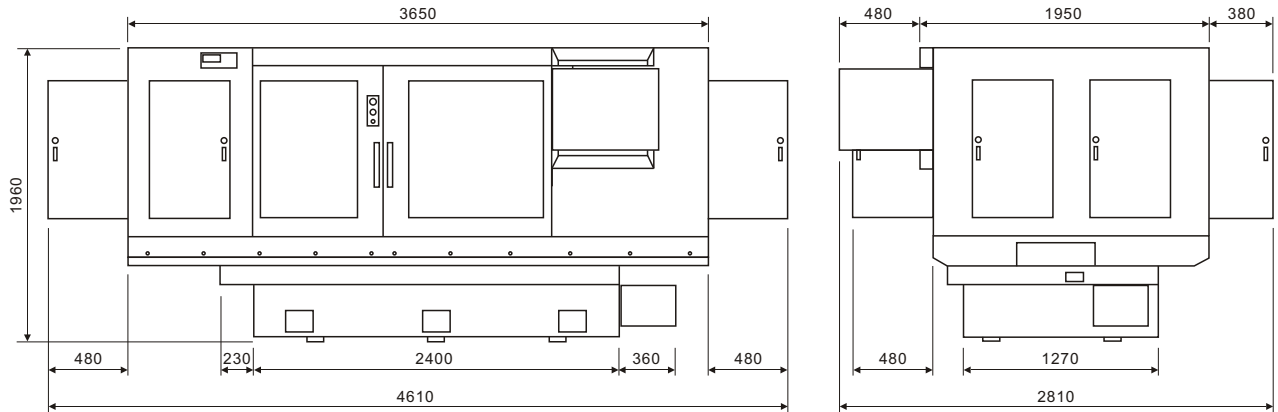

### D1 CNC Multi-Function (ID / OD) Grinder

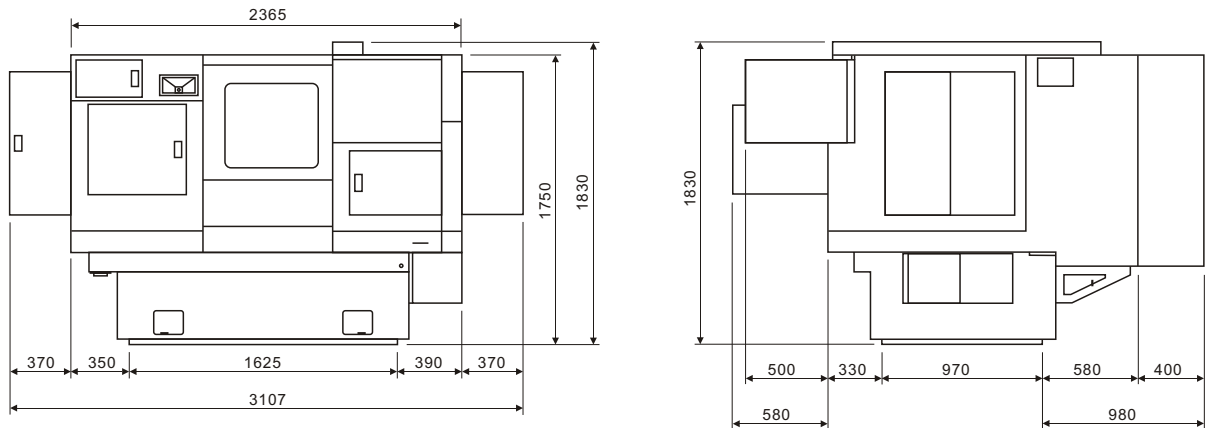

### S10-F CNC Internal Grinder (Full Cover / Semi Cover)

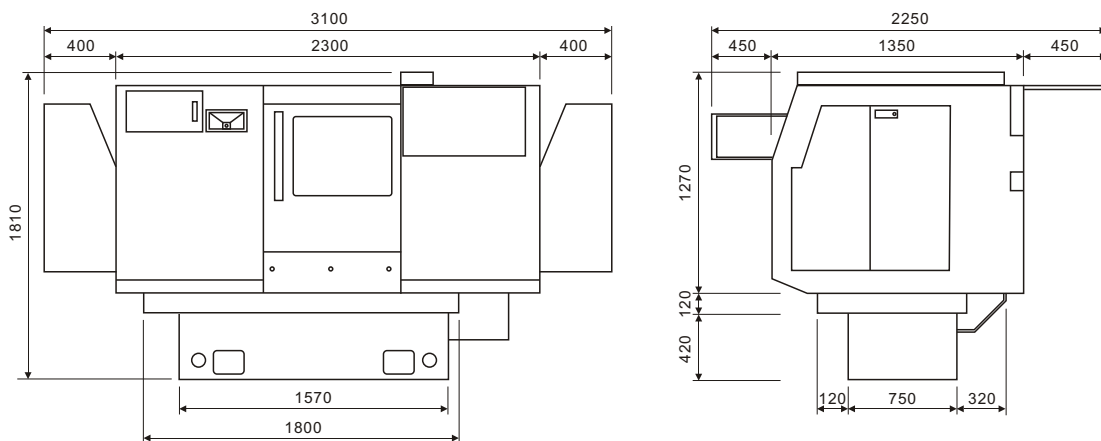



**S10 NC Internal Grinder (Full Cover)**

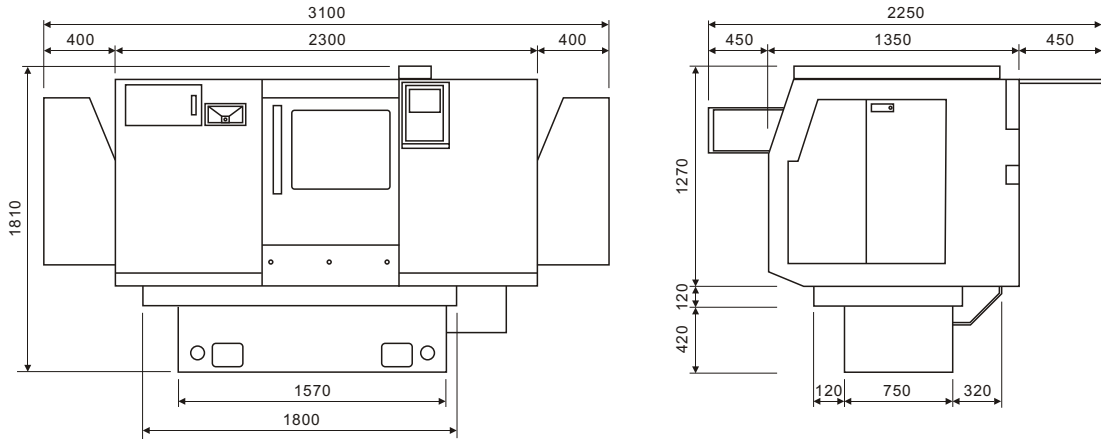

**S10 NC Internal Grinder (Semi Cover)**

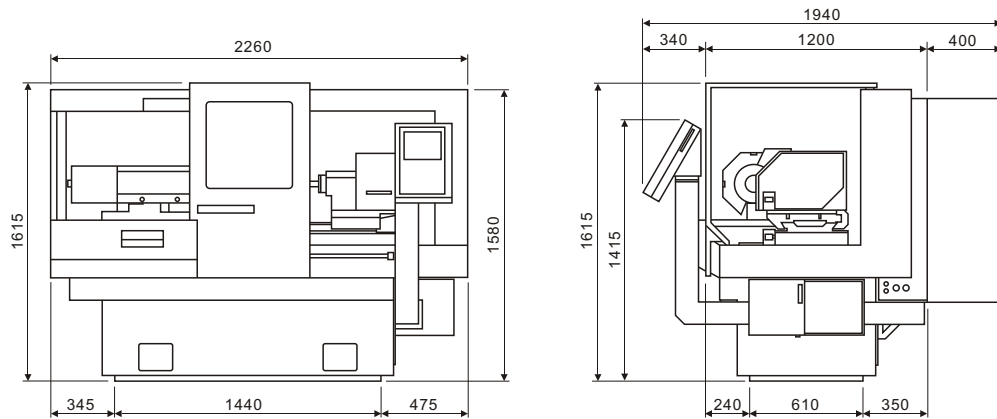

(Unit:mm)

© The above information is based on technical levels of our machine at the time this brochure goes to print. We reserve the right to develop our machines technically and make design modifications. This means that the functions, dimensions, weights, colors, etc. of machines supplied would differ. Diverse application possibilities of our machines depend on technical equipment specifically requested by customers.



**HURISE**<sup>®</sup>  
HURISE CO., LTD.

**鉅陞精機股份有限公司**

No. 16, Jingke 6<sup>th</sup> Rd., Nantun Dist.,

Taichung City, 40852, TAIWAN

TEL: +886-4-23500775

FAX: +886-4-23500776

E-mail: [service@hurise.com.tw](mailto:service@hurise.com.tw)

[www.hurise.com.tw](http://www.hurise.com.tw)