

## Machine Specifications

ITEM		MT-208	MT-208MC	MT-210	MT-210MC
SWING OVER BED	mm	525	525	525	525
OVER CROSS SLIDE	mm	384	384	384	384
MAX. TURNING DIA	mm	350	250	350	250
MAX. WORK LENGTH	mm	500/750	500/750	500/750	500/750
DRAW TUBE DIA	mm	52	52	75	75
CHUCK SIZE	inch	8"	8"	10"	10"
SPINDLE DRIVE MOTOR (cont. /30min.)		7.5/9KW (9/11KW opt.)	7.5/9KW (9/11KW opt.)	9/11KW	9/11KW
SPINDLE SPEED RANGE	rpm	4800	4800	4200	4200
MILLING SPEED RANGE	rpm	-	4000		3800
SPINDLE NOSE	ASA	A2-6	A2-6	A2-8	A2-8
THROUGH SPINDLE HOLE DIA	mm	62	62	90	90
FRONT BEARING DIA	mm	100	100	130	130
SPINDLE TAPER		1/20	1/20	1/20	1/20
X AXIS TRAVEL	mm	185	175	185	175
Z AXIS TRAVEL	mm	537/787	537/787	537/787	537/787
X AXIS MOTOR		1.6KW (2.1HP)	1.6KW (2.1HP)	1.6KW	1.6KW
Z AXIS MOTOR		1.6KW (2.1HP)	3.0KW (3.8HP)	1.6KW	3.0KW
X AXIS RAPID TRAVERSE	m/min	24 (opt.:30 for LINEAR)	24	24	24
Z AXIS RAPID TRAVERSE	m/min	24 (opt.:30 for LINEAR)	24	24	24
GUIDEWAYS		HARD RAIL (LINEAR opt.)	HARD RAIL (LINEAR opt.)	HARD RAIL (LINEAR opt.)	HARD RAIL (LINEAR opt.)
NO. OF TOOL STATIONS		10	12	10	12
SIZE OF EXTERNAL TURNING TOOL	mm	25	20	25	25
BORING BAR DIA	mm	40	40	40	40
QUILL DIA	mm	58	58	58	58
QUILL TRAVEL	mm	88	88	88	88
TAILSTOCK TRAVEL	mm	415/665	415/665	415/665	415/665
QUILL TAPER		MT#4	MT#4	MT#4	MT#4
ELECTRICAL POWER SUPPLY	kva	30	30	30	30
COOLANT TANK CAPACITY	Liter	125	125	125	125
COOLANT FLOW	L/min	15	15	15	15
TOTAL HEIGHT	mm	1700	1700	1700	1700
FLOORSPACE	LENGTH	mm	2300/3100	2300/3100	2300/3100
	WIDTH	mm	1500	1500	1500
NET WEIGHT	kg	3900/4600	3900/4600	4000/4700	4000/4700

All specifications, designs and characteristics shown in this catalogue are subject to change without prior notice.  
Motor specifications are based on machines with FANUC.

### STANDARD ACCESSORIES

- 3-jaw hydraulic chuck
- Hydraulic system
- Hydraulic tailstock
- Live center
- Coolant system
- Morse Taper Sleeve
- Auto lubrication system
- Work light equipment
- Heat exchanger
- Soft jaw
- Foot switch for chuck clamp
- MPG hand wheel
- Operation & maintenance manuals
- Hand tool box
- Levelling pads
- OD tool holder
- Facing tool holder
- Boring bar holder & sleeves
- Drill sleeves

### OPTIONAL ACCESSORIES

- Bar feeder
- Parts catcher
- Tool setter
- C-axis
- VDI turret (without tool holders)
- VDI tool holders
- Auto door
- Chip conveyor
- Chip bucket
- Transformer
- CE mark
- Safety torque limit clutch
- Hoisting hook package
- Levelling kit
- VDI tool holders
- Bar feeder interface (LNS system)
- Additional tool holders and sleeves



## Power Diagram

### Power Diagram

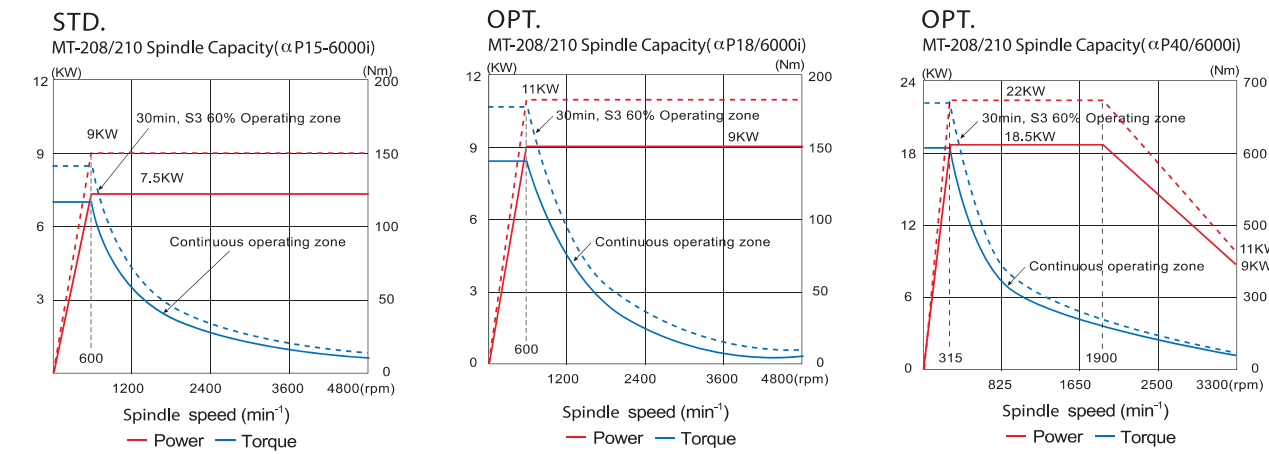

### Power Diagram

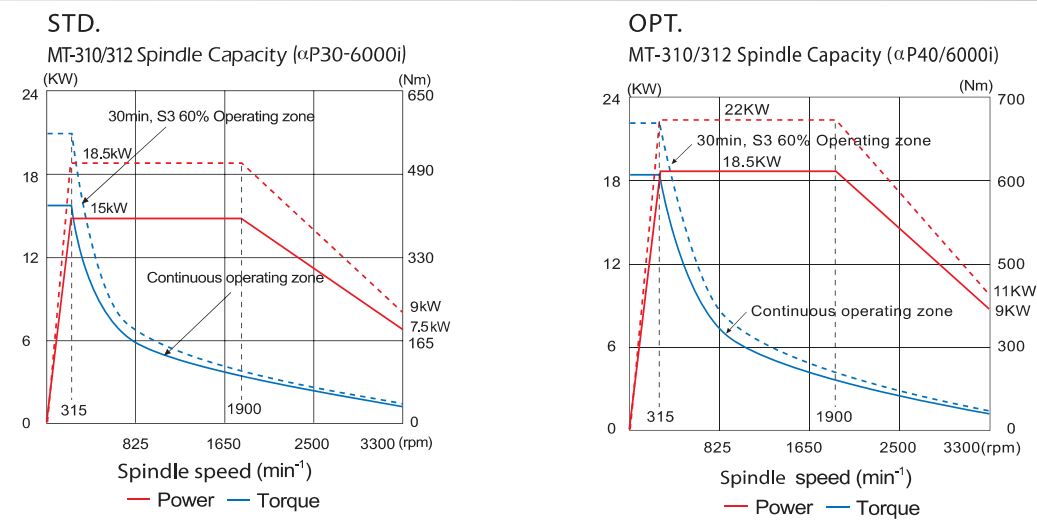

### Power Diagram

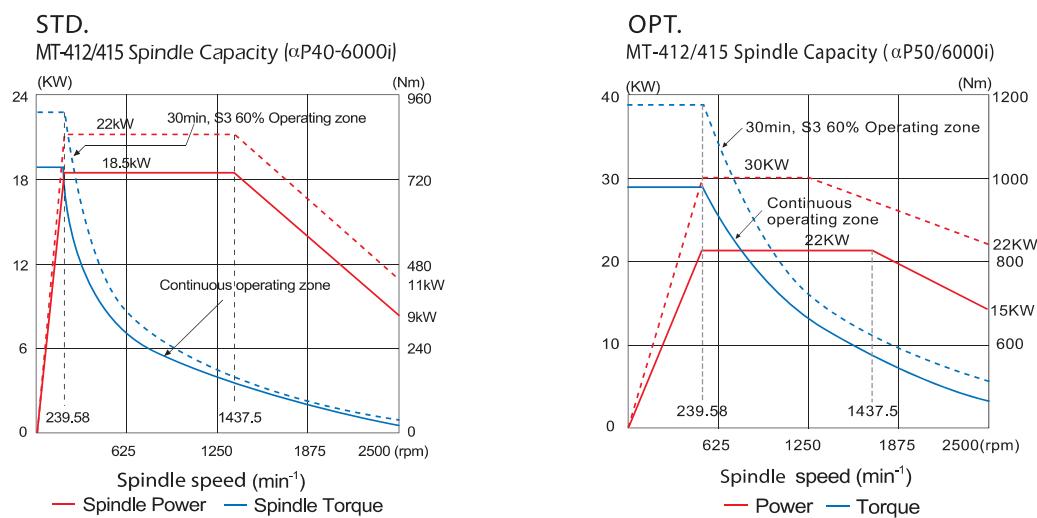

We have consider all the turning applications you might use:  
Wide range of options available for your choice



Parts catcher is available for full automation job. (opt.)

Tool setter from Renishaw provides quick and easy tooling set up. (opt.)

C axis high resolution encoder from FANUC (opt.)

The ECOCA MT series is a very fine integration of high quality and affordable prices.

- 30 degree slant bed design for easy operation and easy chip removal.
- Cast iron bed with optimally designed ribs with integral stiffness provides an very strong rigidity.
- Big diameter bearing provides high rigidity.
- High-resolution encoder mounted on spindle to provide accurate C axis positioning.
- C axis with continuous indexing.
- Double supported ballscrews Direct-driven servo motors are used for axial movements.
- Servo turret or hydraulic turret is offered for users as an alternative choice.
- Large disc is equipped for easy tool set up.
- Special spindle motor location design reduces machine floor space
- One-piece structure on the machine structure to provide massive rigidity.
- Programmable tailstock available as an option.
- When equipped with sub spindle, the main and sub spindles can be synchronized for work piece handover from main to sub spindle. (MT-308MCS)
- Large coolant tank
- Internal coolant supply through turret disc.
- High pressure pump.
- PLC controlled chip conveyor.

# Tool Interference Diagram

## Tool Interference Diagram

unit:mm

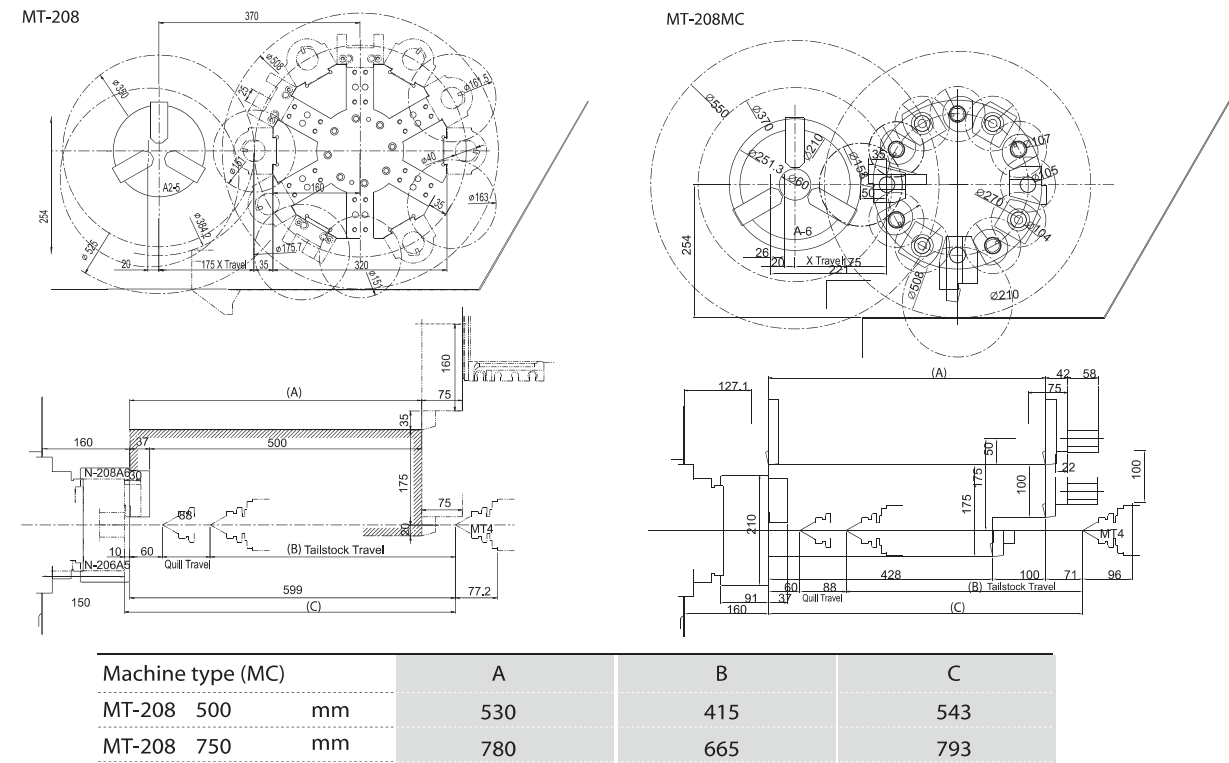

## Tool Interference Diagram

unit:mm

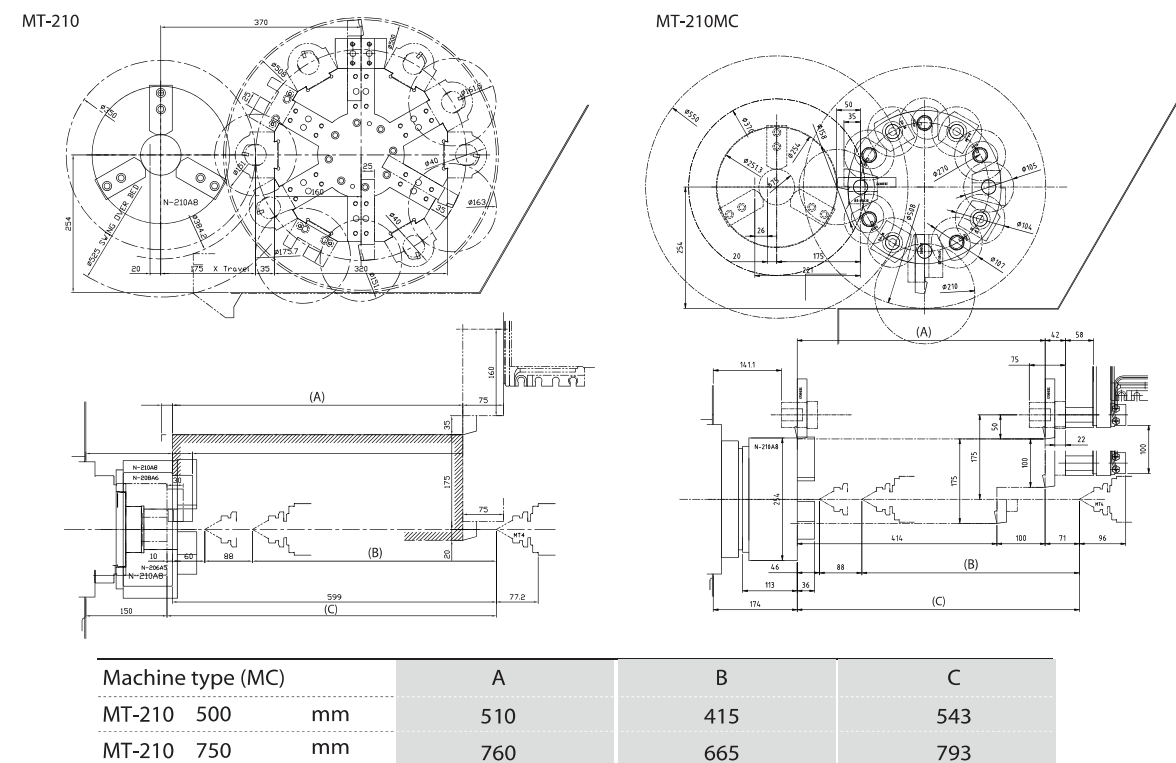

## Tool Interference Diagram

unit:mm

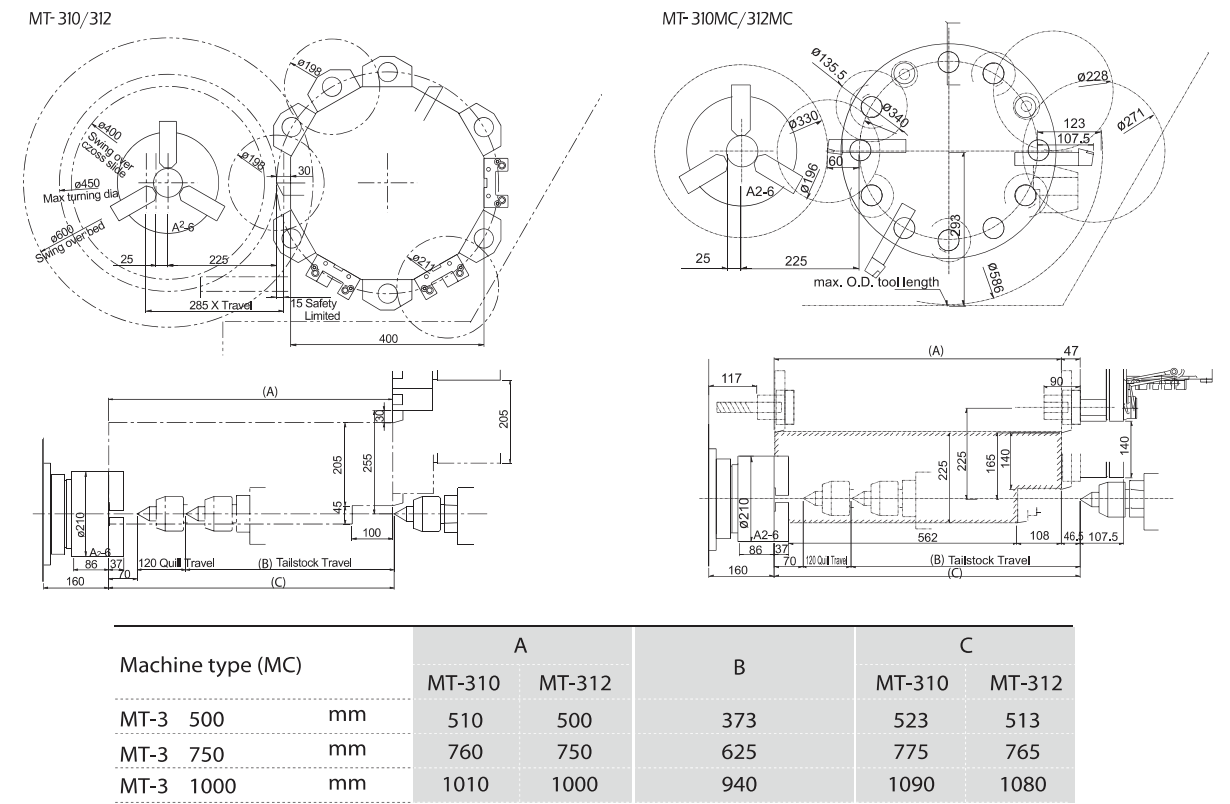

## Tool Interference Diagram

unit:mm

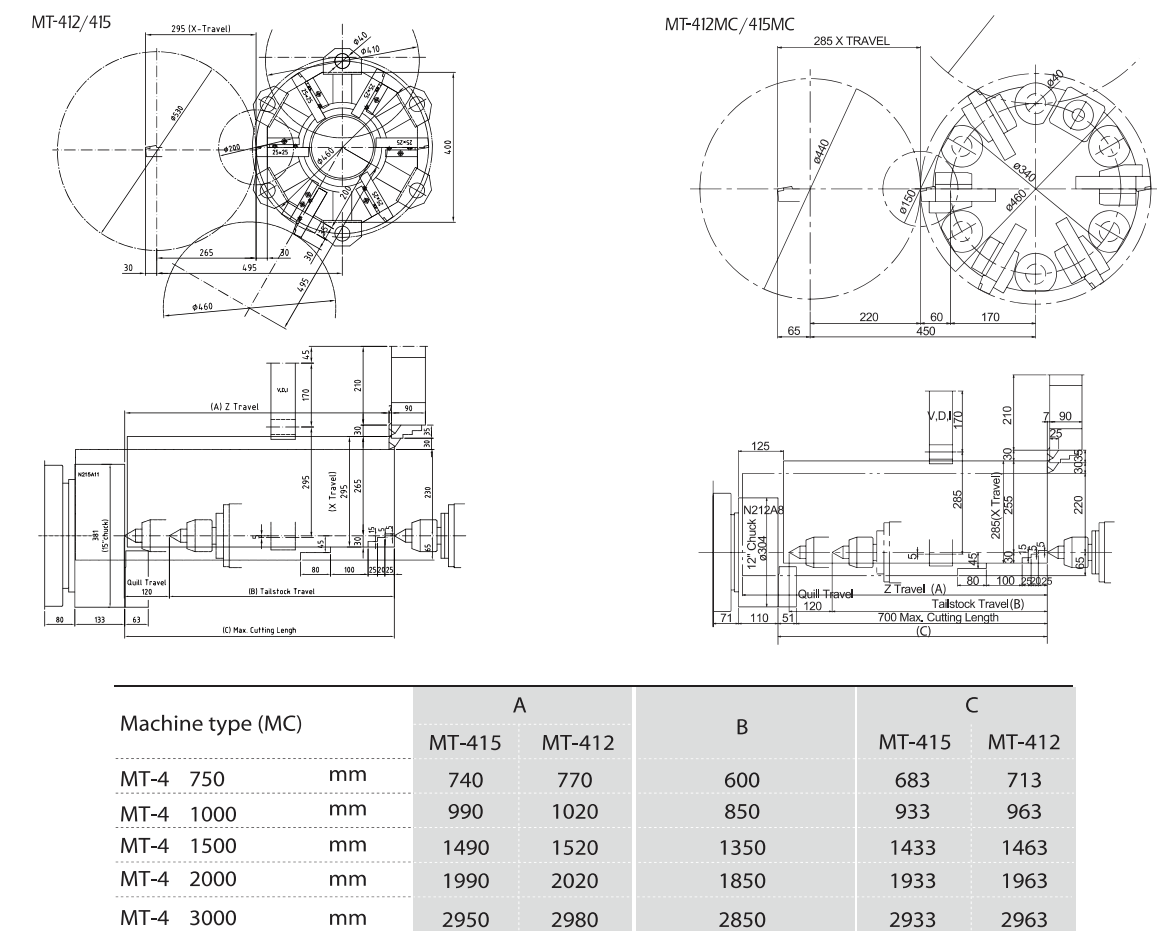

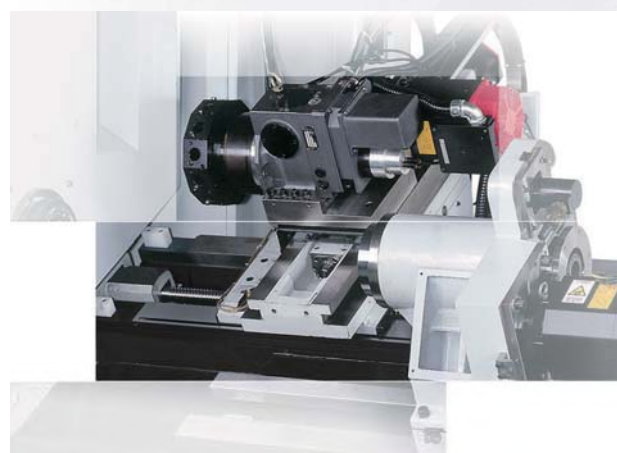
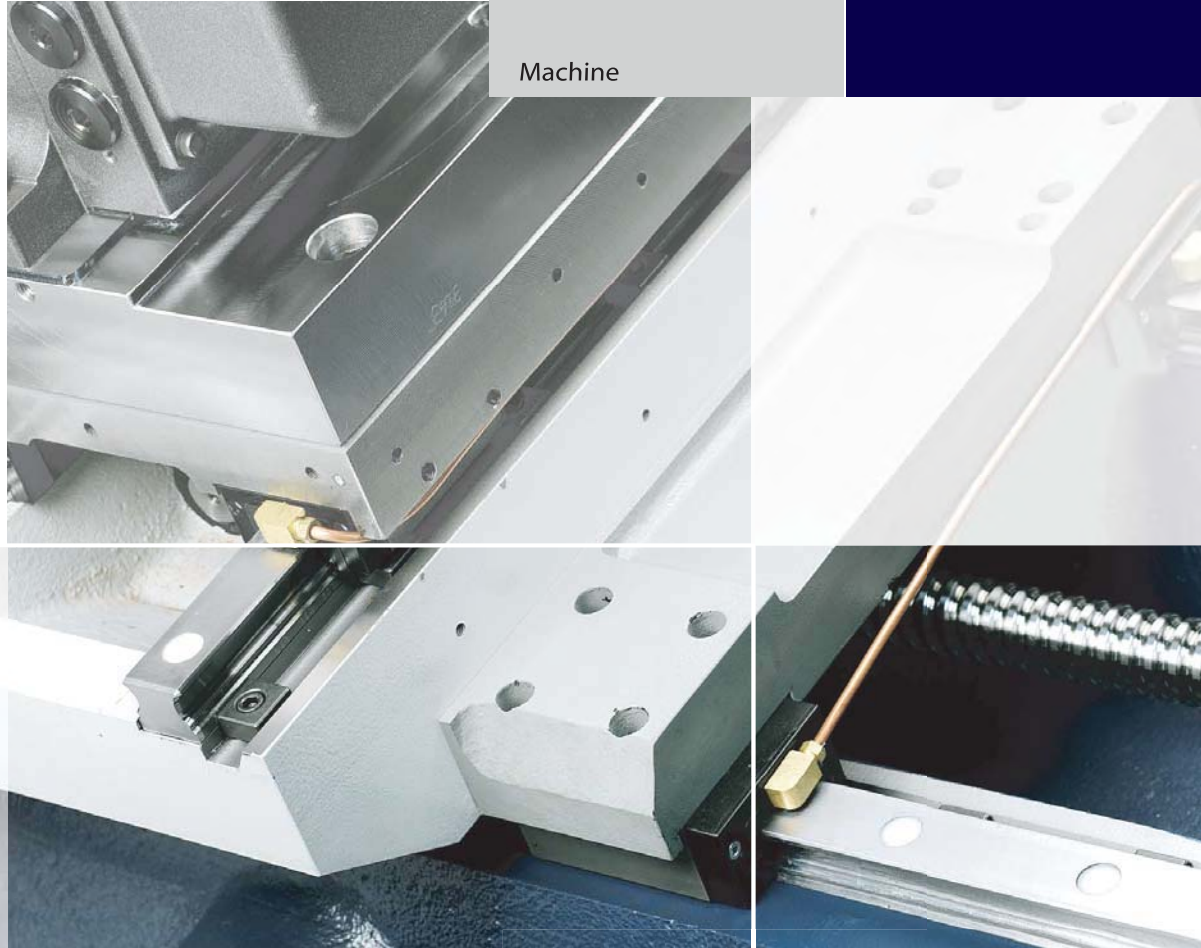

MT-208 big diameter bearing (up to 100mm) provides high rigidity.

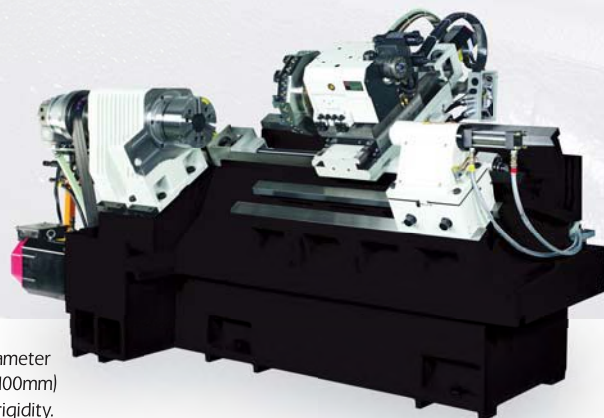

MT-308MCS when equipped with sub spindle, the main and sub spindles can be synchronized for work piece handover from main to sub spindle.

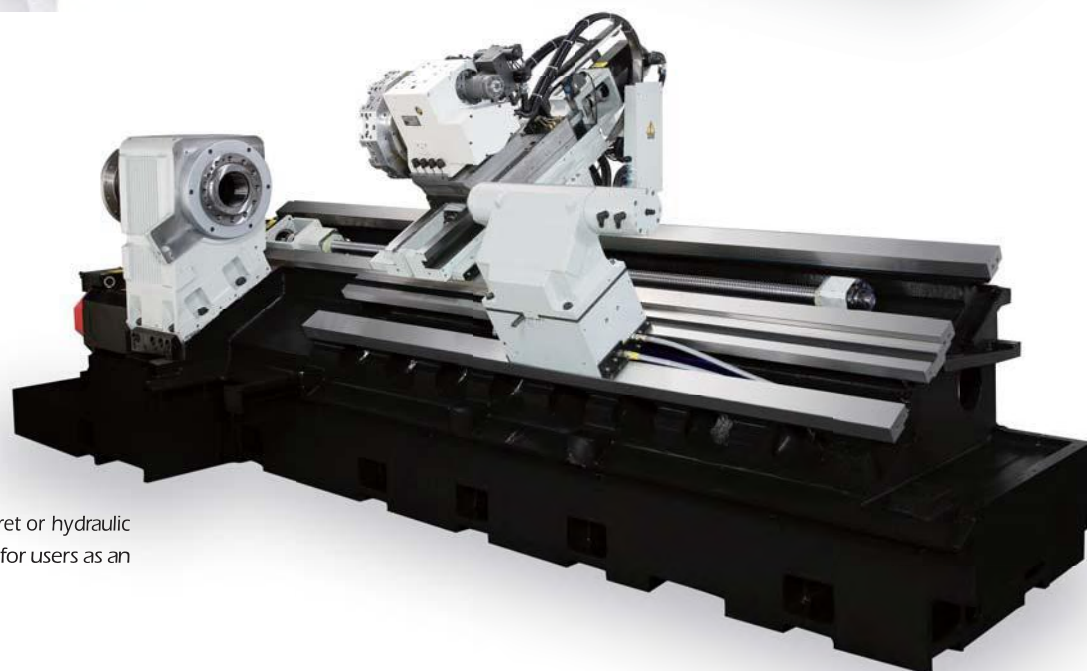

MT-415 servo turret or hydraulic turret is offered for users as an alternative choice.

## Machine Dimensions

Machine Dimensions MT208

unit:mm

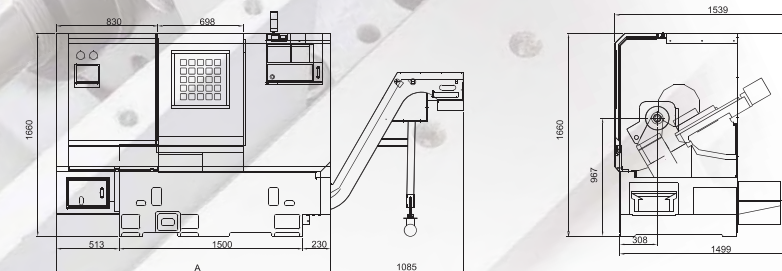

Z axis Spec	500	750
A	2300	3100

Machine Dimensions MT210

unit:mm

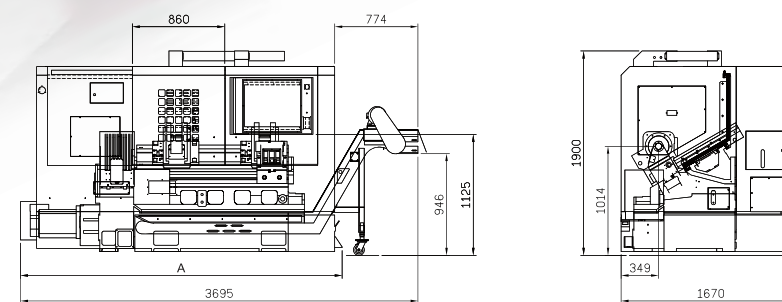

Z axis Spec	500	750
A	2300	3100

Machine Dimensions MT 310/312

unit:mm

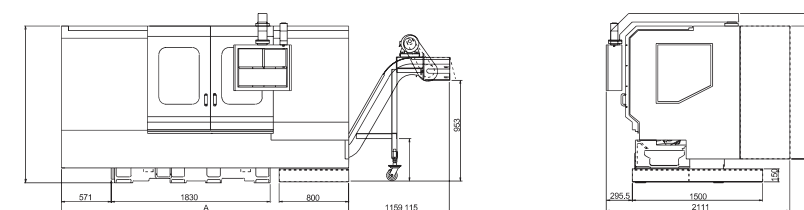

Z axis Spec	500	750	1000
A	2900	3300	3700

Machine Dimensions MT412/415

unit:mm

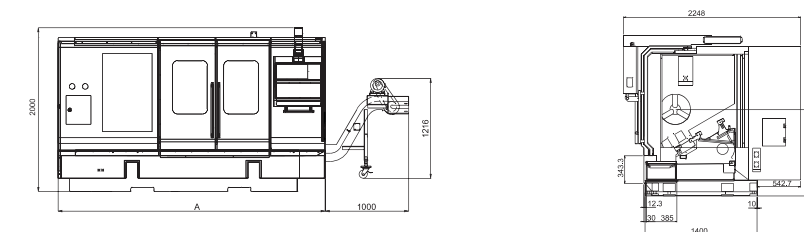

Z axis Spec	750	1000	1500	2000	3000
A	3300	3900	4400	4900	6250

## ECOCA MT-208/210/310/312/412/415 Series

Offering the most solid base to process up to 3000mm turning length, bar capacity up to 117.5mm, and swing up to 700mm over bed, the EcoCA MT series provide the best possible results for CNC lathe operation. The sturdy 30 degree slant bed provides a vibration free operation to the machine. The ergonomically placed spindle, tailstock, and turret provide the operation with the optimal working condition.

Fast and accurate servo-driven turrets. (opt.)

The rigid mechanical configurations yield a very high level of reliability and easy access to the machine operation and maintenance. The EcoCA MT series is a very fine integration of high quality and affordable prices.



Flexible coupling ensures the smooth and accurate movements of the machine.



Fast and accurate servo-driven turrets. (Optional VDI turret)



ITEM		MT-308MCS	MT-310/310MC	MT-312/312MC
SWING OVER BED	mm	600	600	600
OVER CROSS SLIDE	mm	400	400	400
MAX. TURNING DIA	mm	345	450 330	450 330
MAX. WORK LENGTH	mm	750	490/740/990	480/730/980
DRAW TUBE DIA	mm	52	75	91
CHUCK SIZE	inch	8"	10"	12"
SPINDLE DRIVE MOTOR (cont./30min.)		9/11KW(main), 5.5/7.5 KW(sub)	15/18.5KW (18.5/22KW opt.)	15/18.5KW (18.5/22KW opt.)
SPINDLE SPEED RANGE	rpm	4800	4200	3200
SPINDLE NOSE	ASA	A2-6	A2-8	A2-8
THROUGH SPINDLE HOLE DIA	mm	62	90	102
FRONT BEARING DIA	mm	100	130	140
SPINDLE TAPER		1/20	1/20	1/20
MCS SUB SPINDLE SPEED	rpm	6000	-	-
MCS SUB SPINDLE NOSE	ASA	A2-5	-	-
MCS SUB SPINDLE TRAVEL	mm	700	-	-
MC .MCS SUB MILLING SPEED	rpm	3800	3800	3800
X AXIS TRAVEL	mm	225	225	225
Z AXIS TRAVEL	mm	770	510/760/1010	500/750/1000
B AXIS TRAVEL	mm	670	-	-
X AXIS MOTOR		3.0KW (3.8HP)	3.0KW (3.8HP)	3.0KW (3.8HP)
Z AXIS MOTOR		3.0KW (3.8HP)	3.0KW (3.8HP)	3.0KW (3.8HP)
B AXIS MOTOR		3.0KW (3.8HP)	-	-
X AXIS RAPID TRAVERSE	m/min	20	20	20
Z AXIS RAPID TRAVERSE	m/min	20	20	20
B AXIS RAPID TRAVERSE	m/min	20	-	-
GUIDEWAYS		Hard Rail	Hard Rail	Hard Rail
NO. OF TOOL STATIONS		12	12	12
SIZE OF EXTERNAL TURNING TOOL	mm	25	25	25
BORING BAR DIA	mm	40	40	40
QUILL DIA	mm	90	90	90
QUILL TRAVEL	mm	120	120	120
TAILSTOCK TRAVEL	mm	810	560/810/1060	560/810/1060
QUILL TAPER		MT #5	MT #5	MT #5
ELECTRICAL POWER SUPPLY	kva	30	30	40
COOLANT TANK CAPACITY	Liter	150	150	150
COOLANT FLOW	L/min	20	20	20
TOTAL HEIGHT	mm	1905	1905	1905
FLOOR SPACE	LENGTH	mm	4300	2900/3300/3700
	WIDTH	mm	2100	2100
NET WEIGHT	kg	5300	4800/5300/5800	4900/5400/5900

All specifications, designs and characteristics shown in this catalogue are subject to change without prior notice. Motor specifications are based on machines with FANUC.

## MT-208/210/310/312/412/415 Series

ITEM		MT-412		MT-412MC		MT-415		MT-415MC													
SWING OVER BED	mm	680		680		680		680													
OVER CROSS SLIDE	mm	480		480		480		480													
MAX. TURNING DIA	mm	530		440		530		440													
MAX. WORK LENGTH	mm	750	1000	1500	2000	2980	730	980	1480	1980	2960	720	970	1470	1970	2950	700	950	1450	1950	2930
DRAW TUBE DIA	mm	91		91		117.5		117.5													
CHUCK SIZE	inch	12"		12"		15"		15"													
SPINDLE DRIVE MOTOR (cont./30min)		18.5/22KW (22/30KW opt.)		18.5/22KW (22/30KW opt.)		18.5/22KW (22/30KW opt.)		18.5/22KW (22/30KW opt.)													
SPINDLE SPEED RANGE	rpm	3200		3200		2500		2500													
MILLING SPEED RANGE	rpm	-		3200		-		3200													
SPINDLE NOSE	ASA	A2-8		A2-8		A2-11		A2-11													
THROUGH SPINDLE HOLE DIA	mm	102		102		131		131													
FRONT BEARING DIA	mm	140		140		170		170													
SPINDLE TAPER		1/20		1/20		1/20		1/20													
X AXIS TRAVEL	mm	295		295		295		295													
Z AXIS TRAVEL	mm	770	1020	1520	2020	3000	770	1020	1520	2020	3000	770	1020	1520	2020	3000	770	1020	1520	2020	3000
X AXIS MOTOR	KW	4.0(5.3HP)		4.0(5.3HP)		4.0(5.3HP)		4.0(5.3HP)													
Z AXIS MOTOR	KW	4.0(5.3HP)	6(8HP)	4.0(5.3HP)	6(8HP)	4.0(5.3HP)	6(8HP)	4.0(5.3HP)	6(8HP)												
X AXIS RAPID TRAVERSE	m/min	20		20		20		20													
Z AXIS RAPID TRAVERSE	m/min	20 (16m/min for Z axis travel ≥ 1500 mm) (10m/min for Z axis travel ≥ 3000 mm)		20 (16m/min for Z axis travel ≥ 1500 mm) (10m/min for Z axis travel ≥ 3000 mm)		20 (16m/min for Z axis travel ≥ 1500 mm) (10m/min for Z axis travel ≥ 3000 mm)		20 (16m/min for Z axis travel ≥ 1500 mm) (10m/min for Z axis travel ≥ 3000 mm)													
GUIDEWAYS		HARD RAIL		HARD RAIL		HARD RAIL		HARD RAIL													
NO. OF TOOL STATIONS		12		12		12		12													
SIZE OF EXTERNAL TURNING TOOL	mm	25		25		25		25													
BORING BAR DIA	mm	40 (50 opt.)		40 (50 opt.)		40 (50 opt.)		40 (50 opt.)													
QUILL DIA	mm	100		100		100		100													
QUILL TRAVEL	mm	120		120		120		120													
TAILSTOCK TRAVEL	mm	600	850	1350	1850	2850	600	850	1350	1850	2850	600	850	1350	1850	2850	600	850	1350	1850	2850
QUILL TAPER		MT #5		MT #5		MT #5		MT #5													
ELECTRICAL POWER SUPPLY	kva	40	50	40	50	40	50	40	50												
COOLANT TANK CAPACITY	Liter	150	200	150	200	150	200	150	200												
COOLANT FLOW	L/min	20		20		20		20													
TOTAL HEIGHT	mm	2000	2350	2000	2350	2000	2350	2000	2350												
FLOOR SPACE	LENGTH	3300	3900	4400	4900	6250	3300	3900	4400	4900	6250	3300	3900	4400	4900	6250	3300	3900	4400	4900	6250
	WIDTH	2248		2248		2248		2248													
NET WEIGHT	kg	6400	7300	8100	9300	11800	6400	7300	8100	9300	11800	6400	7300	8100	9300	11800	6400	7300	8100	9300	11800

All specifications, designs and characteristics shown in this catalogue are subject to change without prior notice.  
Motor specifications are based on machines with FANUC.



ECOCA INDUSTRIAL CO., LTD.

401, 28TH ROAD, TAICHUNG INDUSTRIAL PARK, TAICHUNG, TAIWAN.

TEL : +886-4-23597666 FAX : +886-4-23597669  
http://www.ecoca.com E-mail : biz@ecoca.com

11-12.22-02/2E-1000-R12

